

HUMAN HEALTH

ENVIRONMENTAL HEALTH

EXCEPTIONAL  
PERFORMANCE  
FOR CHALLENGING  
MERCURY ANALYSES



**FIMS 100 and 400**  
Flow Injection Mercury Systems





## FIMS 400 Flow Injection Mercury System

The determination and monitoring of sub-ppb concentrations of mercury has always been of special importance in the field of trace metal analysis. For more than 500 years, mercury has been recognized as a poison. Today, mercury pollution is a global problem. To control the amount of mercury polluting our environment, mercury has to be monitored in all areas of modern life. This requires fast, cost-efficient and easy-to-use methods and instrumentation that permit the determination of mercury at levels as low as a few ng/L.

PerkinElmer pioneered the field of atomic absorption (AA) and continues its worldwide leadership in this critical segment of analytical science. The PerkinElmer® Flow Injection Mercury Systems (FIMS) combine the advantages of flow injection and atomic absorption measurement into a compact mercury analyzer. FIMS offers you the convenience and the exceptional performance you need to meet today's most demanding productivity challenges and regulatory requirements.

## High throughput for improved productivity

Whether you have just a few or hundreds of mercury samples to analyze, the FIMS can improve your laboratory productivity by providing up to 2 determinations per minute. With an optional autosampler, up to 270 samples can be analyzed automatically in any desired sequence.

## Freedom from interferences for improved accuracy

By combining the advantages of the flow-injection technique and atomic absorption detection, the FIMS provides a freedom from interferences that is unachievable by other mercury techniques. Since the analyte is separated from the matrix, analyses are virtually interference-free.

## Exceptional performance

By incorporating a high-sensitivity spectrometer with a high-intensity mercury lamp and a long path absorption cell with a solar-blind detector, the FIMS provides exceptional sensitivity and stability with extremely low noise. This means exceptional detection limits in any matrix.

FIMS systems include either one (FIMS 100) or two (FIMS 400) independently controlled peristaltic pumps for carrier, reagent and sample transport; a 5-port flow injection (FI) switching valve; and other high quality FI components. The easily replaced sample loop is available in a variety of sizes.

The built-in automatic baseline offset correction (BOC) system corrects the baseline immediately prior to each measurement, providing phenomenal short and long term stability. As a result, the FIMS provides routine mercury detection limits of less than 5 ng/L. Hence, most samples can be analyzed without the need for sample preconcentration.

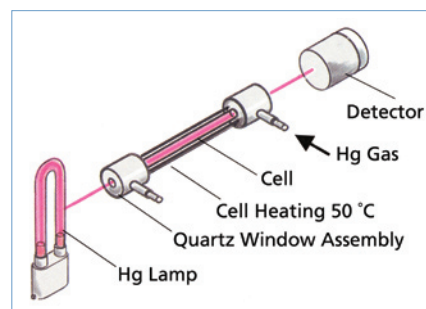

Figure 2. FIMS optical diagram.

## QUICK GLANCE

- High sample throughput
- Freedom from interferences
- Superior detection limits
- Large sampling capacity
- Lower operating costs
- Amalgamation compatible
- Compact design
- Powerful WinLab32 for AA software

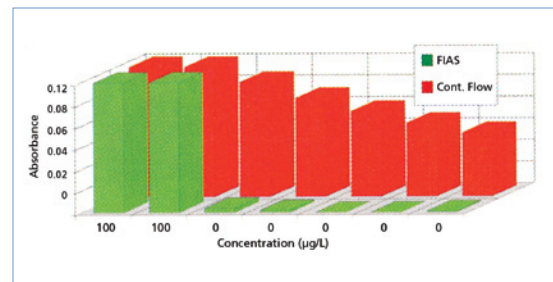

Figure 3. Measurements of very high Hg concentrations with FIMS showing extremely low memory effects compared with continuous flow techniques.

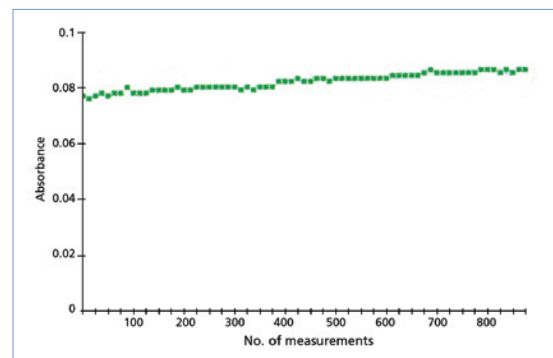

Figure 4. FIMS long-term stability. Each data point represents the average of 11 measurements (5 µg/L Hg, 120 measurements per hour).



# Flow Injection – a Better Approach

The flow injection principle used in the FIMS is illustrated in the diagram below. The peristaltic pumps are used to deliver the carrier and reductant streams and for waste removal. When the FI valve is in the FILL position, the sample loop is filled with an exact volume of sample. When the valve is switched to the INJECT position, the sample is introduced into the carrier stream and transported to the mixing section for reaction with  $\text{SnCl}_2$  or  $\text{NaBH}_4$ . The resulting reaction mixture is then carried to a gas/liquid separator where the elemental mercury is liberated and, after passing through the polytetrafluoroethylene (PTFE) filter, is transported to the absorption cell by an argon carrier gas.

## Exceptionally low carryover

Unlike continuous-flow designs, the flow injection technique results in considerably reduced carryover. The result is shorter washout times and improved analytical accuracy.

## Reduced operating costs

Not only does the FIMS provide the performance and ease-of-use that your laboratory needs, it helps you improve your bottom line by reducing operating costs.

With the FIMS flow injection system, much smaller sample volumes are required than batch or continuous flow techniques. This results in lower reagent consumption thereby reducing your daily operating expenses. Lower reagent consumption also reduces waste material disposal costs, further reducing costs. The FIMS uses less carrier gas than continuous flow systems and even automatically stops flow after 10 minutes of inactivity.

With the FIMS, your cost savings begin the first day you use it.

## Minimal bench space requirements

Due to its integrated compact design, the FIMS requires very little of your valuable laboratory bench space.

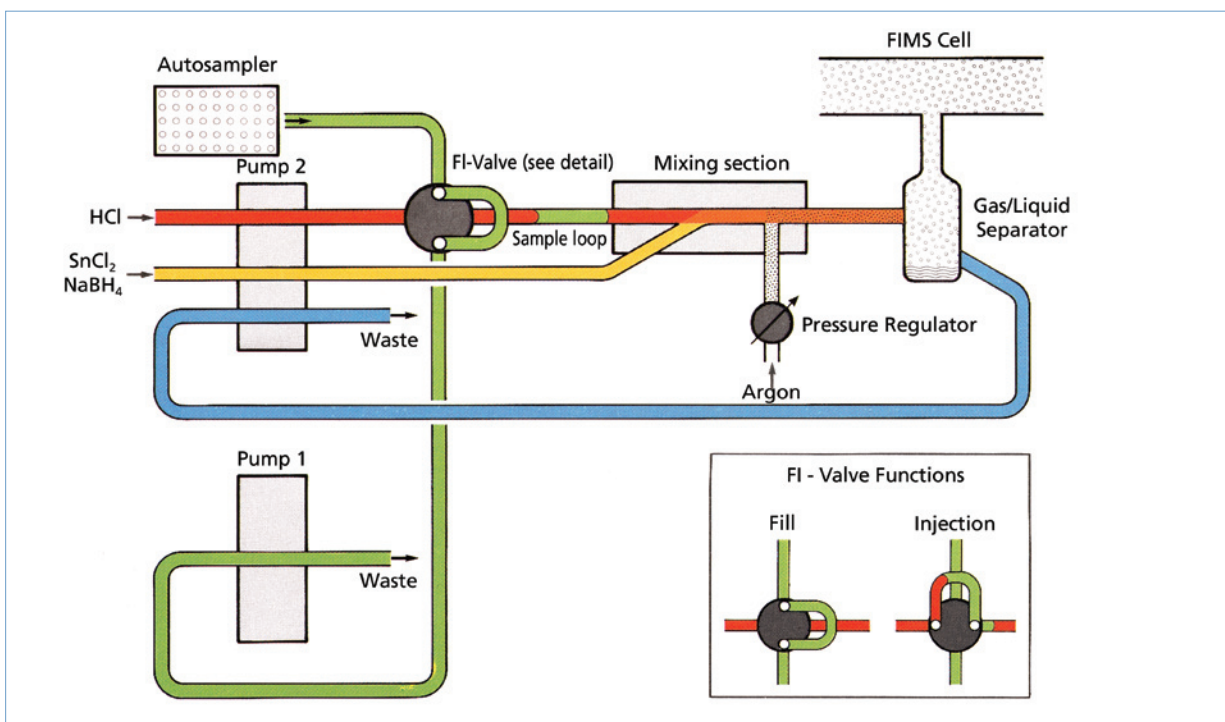

Figure 5. FIMS flow diagram.

# Flexible, Easy-to-Use Design

FIMS systems are designed to provide the flexibility required to meet your varying analytical needs.

Some of the flexibility features include:

- Independently controlled peristaltic pumps
- Individually adjustable tubing pressure
- Interchangeable tubing cassettes
- A variety of sample loop sizes available
- Modular mixing section adaptable to different applications
- Carrier gas adjustable from 40 to 250 mL/min

Best of all, you can even use your FIMS with an AAnalyst™ or PinAAcle™ atomic absorption spectrometer to determine hydride-forming elements such as As and Se.

With the FIMS, you will have complete flexibility.



Figure 6. Easy interchange of FIMS absorption cell.



Figure 7. Quick, simple access to mercury light source.

## Easy to use and maintain

The design and modularity of the FIMS makes it easy to use and maintain.

With the FIMS, a PTFE membrane and a cell heated to 50 °C prevent the transfer and condensation of water vapor, eliminating the need for cumbersome drying tubes for most applications.

The cell assembly is easily removed for maintenance and, should you ever need to replace the mercury source lamp, this can be simply done in less than 5 minutes.

## Powerful system software

The FIMS system and its accessories are controlled using PerkinElmer's powerful, standard-setting WinLab32™ for AA software. A few WinLab32 for AA features include:

- Common look and feel with WinLab32 for ICP for easy cross-platform use
- Extensive QC options ensure data quality
- Data Export allows selected data results to be transferred to a network computer
- A vast array of multi-language Tool Tips for ease-of-use
- Workspaces for storing your configurations
- 21 CFR Part 11 compliance with optional Enhanced Security™ software
- Full alpha-numeric sample identification
- Extensive on-line Help

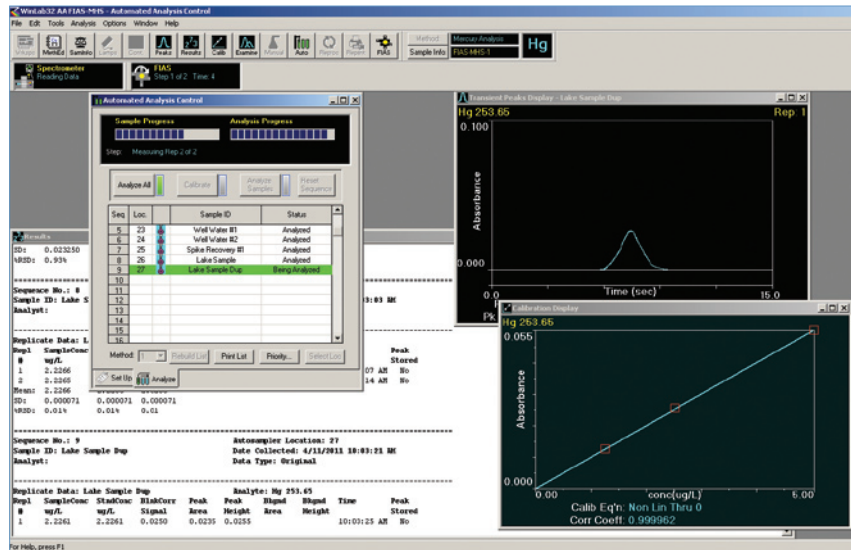

Figure 8. WinLab32 for AA software.

# Accessories Provide Limitless Flexibility

## Automatic amalgamation for sub-ppb detection limits

While the FIMS provides exceptional mercury detection limits (i.e., < 5 ng/L), some samples and regulations require sub-ppb detection limits. By simply adding an optional computer-controlled amalgamation system, detection limits can be further reduced more than an order of magnitude.

Utilizing a fine Au/Pt gauze, the amalgamation system concentrates the mercury released by the cold vapor technique of the FIMS. Following concentration, the gauze is rapidly heated and the mercury is transported to the FIMS cell, with a resulting significant reduction in detection limits. The total amount of mercury collected on the gauze determines the final detection limit.

## S10 autosampler offers exceptional sampling capacity

The S10 autosampler automates standard and sample introductions for instrument calibration and sample analysis, extending the capabilities of the FIMS to those of a fully automated analytical workstation. The S10 autosampler comes with a self-rinsing sampling probe and the flexibility to select from multiple tray configurations. An advanced drive system moves the sampling arm in the X and Y coordinates simultaneously, minimizing changeover time between samples. Random access gives you exceptional flexibility in the placement of samples and reference solutions. Corrosion-resistant sampling components are made entirely of acid- and solvent-resistant materials, ensuring longer life. With the S10 autosampler, a built-in peristaltic pump permits continuous rinsing of the sampling capillary between samples, significantly reducing the risk of carryover. In addition to the standard sample trays, the S10 autosampler is compatible with trays from many third-party suppliers, providing increased flexibility.



Figure 9. Optional amalgamation accessory.



Figure 10. S10 autosampler.

## FIMS Flow Injection Mercury System – Specifications

System Description	Automated atomic absorption spectrometer with integrated flow injection system for cold vapor mercury AA. Single beam optics with automatic baseline offset correction (BOC) immediately before each measurement, low pressure Hg lamp and solar-blind detector with maximum sensitivity at 254 nm. Built-in supply and control electronics based on surface mounted device (SMD) technology for fully automated operation. The FIMS 100 system is provided with 1 pump. The FIMS 400 system is provided with 2 pumps.
System Control	Full control of the spectrometer, FI components, autosampler and other accessories via an industry standard personal computer using the PerkinElmer WinLab32 for AA system software based on the Microsoft® Windows® operating environment.
Transport of Reagents	Stepper-motor driven peristaltic pumps with a maximum of 8 channels each for tubing with 0.13 to 3.18 mm inner diameter. The speed of revolution is selectable from 20 to 120 rpm.
Sampling and Flow Switching	FI switching valve with 5 ports and exchangeable sample loops.
Gas Supply	Carrier gas stream (argon) flow controlled from 40 to 250 mL/min by flow meter. Required inlet pressure: 320-400 kPa. Automatic switch-off after operating pauses of more than 10 min.
Absorption Cell	Long-path glass absorption cell (240 mm long, 7 mm O.D., 4 mm I.D.) with removable quartz windows.
Cell Heating	Electrically heated mantle around the cell to maintain the cell at approx. 50 °C to prevent vapor condensation.
Data Connection	Built-in IEEE-488 and RS-232C interfaces. Addressing and switch over between IEEE and RS-232C by DIP switches.
Remotes	9 output contacts, which can be activated independently; e.g. for control of the amalgamation accessory.
Power Requirements	115 VAC or 230 VAC, 50/60 Hz, 450 VA.
Technical Standards	Classified as a laboratory instrument. Complies with the applicable European Union directives and standards for safety and electromagnetic compatibility for CE marking. The instrument has been developed and is produced in compliance with ISO 9001.
Weight	19 kg.
Dimensions (WxHxD)	42 cm x 26 cm x 41 cm (including sample tray).

## Amalgamation Accessory – Specifications

Principle	Amalgamation of mercury on a gold/platinum gauze and fast release of mercury by heating the gauze using an infrared heat source.
Heating Temperature	Approximately 600 °C.
Cooling	By means of a flow of compressed air.
Carrier Gas Flow	75 or 300 mL/min.
Operation	Times for collection, heating, cooling and flushing can be freely selected via the FIMS system.
Power Requirements	115 VAC or 230 VAC, 50/60 Hz, 300 VA.
Weight	4.9 kg.
Dimensions (WxHxD)	25 cm x 25 cm x 24 cm.

## Expect more from the leader in atomic spectroscopy

PerkinElmer has been at the forefront of atomic spectroscopy technology for over 50 years. No matter what your field, application or sample type, we have the tools and expertise to help you achieve accurate results quickly, efficiently, effortlessly.

With tens of thousands of installations worldwide, PerkinElmer systems are performing inorganic analyses every hour of every day. So turn to the most trusted name in the industry. And take advantage of a complete array of solutions engineered for unparalleled performance, accuracy and confidence. For more information on our full suite of atomic spectroscopy products and services – including a wide array of mercury analyzers and sample preparation tools – please visit [www.perkinelmer.com/atomic-spectroscopy](http://www.perkinelmer.com/atomic-spectroscopy).

## OneSource Laboratory Services

PerkinElmer's OneSource® is the market leading laboratory asset management solution, pioneered more than a decade ago with more than 400,000 multivendor assets under its care. OneSource Laboratory Services goes beyond just maintenance and repair of instrumentation. OneSource incorporates laboratory asset management as part of our customer's business equation – a partner with proven results in improving efficiencies, optimizing operations and providing cost certainty across the globe. **The ONE you can count on.**

PerkinElmer, Inc.  
940 Winter Street  
Waltham, MA 02451 USA  
P: (800) 762-4000 or  
(+1) 203-925-4602  
[www.perkinelmer.com](http://www.perkinelmer.com)



For a complete listing of our global offices, visit [www.perkinelmer.com/ContactUs](http://www.perkinelmer.com/ContactUs)

Copyright ©2003-2011, PerkinElmer, Inc. All rights reserved. PerkinElmer® is a registered trademark of PerkinElmer, Inc. All other trademarks are the property of their respective owners.

006858B\_01