

**ESCO**

WORLD CLASS. WORLDWIDE.



# Ascent • Series

## **Ductless Fume Hoods**

*The Safe, Energy Efficient Solution for Modern Chemistry*

About Esco ..... 02

Esco Ductless Fume Hoods ..... 03

Why Esco Ductless Fume Hoods? .... 03

Esco Nanocarb™ Filters ..... 04

Esco Chemical Guide ..... 05

Ductless Fume Hood Standards ..... 05

Save Expensive Lab Ventilation Costs and Energy..... 06

Sentinel Microprocessor Control, Alarm, Monitoring System ..... 07

Computational Fluid Dynamics .... 07

General Applications for Ductless Fume Hoods ..... 08

Ascent Series Ductless Fume Hoods Product Lineup ..... 09

Esco Ascent™ Max Ductless Fume Hood ..... 10

Esco Ascent Opti™ Ductless Fume Hood ..... 18

Esco Powdermax® Powder Weighing Balance Enclosure ..... 22

FiltraCheck™ Application Advisory Service ..... 23

Carbon Filter ..... 24



**About Esco**

Since Esco was founded in 1978 our company has earned a reputation for innovation in the worldwide laboratory equipment and cleanroom industry. Today, Esco has emerged as a market leader in containment, clean air and laboratory equipment technologies with active sales in more than 100 countries and direct company offices in the top ten geospecific markets.

From our headquarters in Singapore, Esco directs a highly efficient research, product development, manufacturing and customer service program. We are the only company in our market that is completely configured to export most of what we manufacture.

And because of our worldwide presence, and because we listen carefully to our customers and our distributors, you can have confidence that Esco products represent the best thinking in the world.

Esco is a story of hard work and entrepreneurship, empowerment of others, attention to detail and managing opportunity in response to world events. Our story is affirmed each day by many individuals born of cultural and ethnic diversity. Ours is a story of technical invention and imagination played out over a geographic expanse so broad that the sun never sets on what we do.

Our many languages and cultures, customs and traditions, and modern business management techniques blend into a single effort focusing on customer service, one customer at a time. As you learn more about Esco, you will understand why World Class. Worldwide. is more than a phrase. It's part of who we are, where we are from and where we are going.

## Esco Ductless Fume Hoods

Esco Ascent Ductless Fume Hoods provide protection to both laboratory personnel and the environment from toxic fumes and are quickly becoming a viable alternative to conventional fume hoods.

Unlike conventional fume hoods, these hoods filter out chemical fumes and recycle air directly back to the laboratory, providing energy savings, personnel and environmental protection, convenience as you do not have to deal with complicated ducting systems, and mobility, as ductless hoods are independent systems which do not require connection to extraction systems.

Esco ductless fume hoods are independently tested by INVENT-UK for the ability to filter contaminated air with efficiency and retention capacity as required by the British Standard BS 7989 and French Standard AFNOR NF X 15-211. Fume containment and airflow uniformity meet the requirements of ASHRAE 110-1995, BS 7258, EN 14175-3 and AFNOR NF X 15-203. The Esco combination of effective containment and safe carbon filtration opens new, cost effective applications for fume hood technology in laboratories of the 21st century.

### Why Esco Ductless Fume Hoods?



#### **The "GREEN" solution**

- Environmentally friendly
- Does not discharge toxic gases to the environment
- Saves energy, and reduces total carbon footprint



#### **Safe carbon filtration**

- Compliance to international standards
- Proprietary Nanocarb™ activated carbon technology
- Industry-unique dual diffuser system on our Ascent Max fume hoods optimizes carbon filter life
- Optional VOC sensor system on our Ascent Max hoods detects filter saturation
- FiltraCheck™ service to qualify your application's suitability for a ductless solution
- Chemical Guide provides list of chemicals with specific suitability and safety data



#### **Low cost**

- No ductwork required
- No exhaust system required
- Saves the need for elaborate make-up air systems, in turn saving running costs required to condition make-up air



#### **Convenience**

- No installation hassle
- Mobile, flexible and easily relocatable



## Esco Nanocarb™ Filters



Esco's Nanocarb™ activated carbon filters are constructed in order to ensure maximum filter efficiency, retention capacity and operator protection. Esco's research scientists and engineers, working in consultation with world-leading authorities on adsorption science, have developed the following set of unique technologies:

- Optimized retention capacity (i.e. the total weight of chemicals the filter can retain, usually as a percentage of its own weight) considering that activated carbon may have an increased adsorption capacity by weight, yet poorer overall filtration performance for the actual application. By considering the Isotherms of various activated carbon materials, Esco scientists have selected the optimum grade(s) of raw materials in order to achieve the best balance of all performance factors.

- Continuous incoming quality control tests on all activated carbon raw material procured.
- Generously sized filters with more activated carbon by weight retain more chemicals and last longer.
- Proprietary computer modelling software to predict application suitability, filter saturation capacity, and efficiency for single and multiple compounds.
- Rigid, sheet metal construction coupled with a flat-packed bed to minimize dusting and ensure even air-flow through the filter.
- Quick-changeout filter clamping mechanism allows filter replacements to be carried out with minimal tools; even filter clamping (perimeter, not point force) prevents leaks from occurring.



- Diffusion technology (US patent pending) to ensure even filter loading.
- Optional sensing technology (US patent pending) is available as an aid to predict filter breakthrough and warn the user to change the filters.
- Filters are individually installed onto each fume hood and certified at the factory before shipment.

4

### Nanocarb™ Filter Options

Code	Name	Suitable Applications
<b>A</b>	Standard Filter	All common laboratory chemicals, especially with organics. When no specific requirements are present, or when more than one type of chemical is used.
<b>B</b>	Acid Filter	Applications involving sulphur dioxide, hydrofluoric acid fumes. Removes inorganic / organic acid vapours and fumes.
<b>C</b>	Mercury Compounds Filter	Highly effective for removal of mercury vapour and compounds. (Stable, non-volatile mercuric sulphide filter media).
<b>D</b>	Sulphur Compounds Filter	Removal of sulphur compounds.
<b>E</b>	Halogen Compounds Filter	Removal of halogen compounds like Chlorine, Fluorine, Iodine, Bromine, Astatine etc.
<b>F</b>	Aldehyde Filter	Formaldehyde applications or when aldehydes are present. Hospital pathology and endoscopy applications.
<b>G</b>	Ammonia / Amines Filter	High performance removal of ammonia/amines by chemisorption.
<b>Optional HEPA Filter (ADC_E_Models Only)</b>		HEPA filter with a typical efficiency of 99.99% removes particulates and aerosols. Ductless fume hoods with HEPA filters are suitable for cleanroom applications, or may be used as a Class I Biological Safety Cabinet.
<b>Optional Secondary Backup Carbon Filter (ADC_C_Models Only)</b>		When installed, hood complies with the requirements of ANSI/AIHA Z9.5-2003.

## Esco Chemical Guide

You might have concerns over which filters to choose for specific chemicals, as there are hundreds of different types of activated carbon in the world, each made for different specific applications. Esco's Chemical Guide is a list of most commonly used laboratory chemicals and reagents, arranged in alphabetical order. Each chemical has been thoroughly studied by Esco's research scientists and engineers, and its suitable Nanocarb™ activated carbon filter indicated.

*Note: Each Esco Ascent Ductless Fume Hood is delivered with a Chemical Guide.*

**Instructions for Use**

CHOICE OF FILTER

A	B	C	D	E	F	G
1						

1 Suitable for use

2 Moderate adsorption, need frequent monitoring

! Toxic/ explosive/ not suitable for use with ductless fume hoods

**Esco** Consult us

**HP** HEPA Filter

---

*EXAMPLE 1*

1 Identify the chemicals you will most commonly use for your applications  
*Eg:* 1. Acetone - 2. Allyl Alcohol

2 Check Chemical Listing Booklet for most suitable filter

**Acetone** - Check page  →

A	B	C	D	E	F	G
1						

**Allyl Alcohol** - Check page  →

A	B	C	D	E	F	G
1						

*Conclusion: Purchase Esco Ascent Ductless Fume Hood with Code A carbon filter*



*This chemical guide, combined with our FiltraCheck™ Application Advisors Service (more information on Page 14 & 15), will ensure that you are using the right filter for your application.*

Esco Ascent Ductless Fume Hoods have been independently tested and comply with all major international standards.

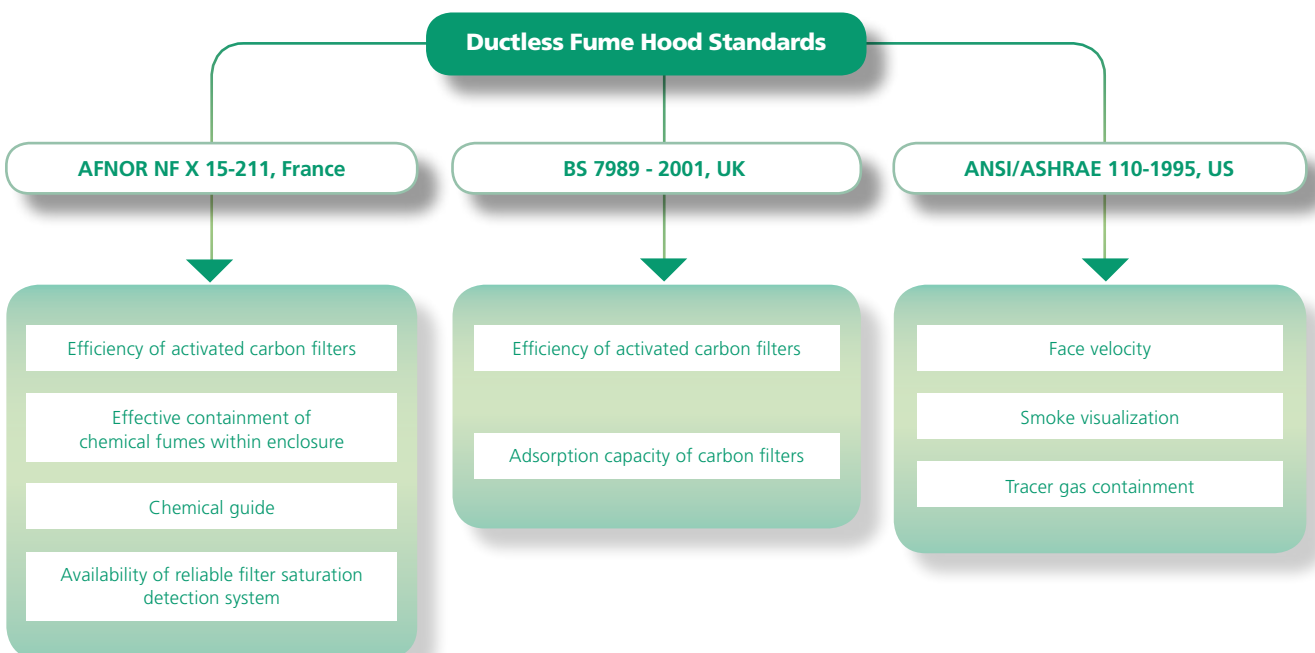

## Save Expensive Lab Ventilation Costs and Energy

Comparison between Conventional Fume Hood and Ductless Fume Hood					
		Conventional Ducted Hood	<i>Energy Efficient</i> Ductless Fume Hood (Integrated Fan & Filter)	Remarks	
Initial Capital Costs	A	Ductwork	US\$ 1500	None	Efficient carbon filtration system means potentially complex ducting systems are not required.
	B	External Exhaust Blower	US\$ 800	None	Compact integrated fan is sufficient to overcome the pressure drops across carbon filters.
	C	Make-up Air System	US\$ 2000	None	No exhaust means conditioned air is not drawn out of the lab expensive make-up air system with chiller/ heater and dehumidifier is not required.
<b>Net Initial Capital Cost Savings: US\$ 4300</b>					
Annual Running Costs	D	External Exhaust Blower	US\$ 2000	None	Energy requirements for small integrated blower is significantly less than that of large external exhaust blower.
	E	Integrated Exhaust Blower	None	US\$ 100	
	F	Make-up Air System	US\$ 3000	None	Conventional fume hoods consistently draw conditioned air out, giving rise to high energy consumption of make-up air system.
	G	Carbon Filter	None	US\$ 600	Assuming customer changes filters once a year, running costs are still low in comparison.
<b>Net Annual Running Cost Savings: US\$ 4300</b>					

6

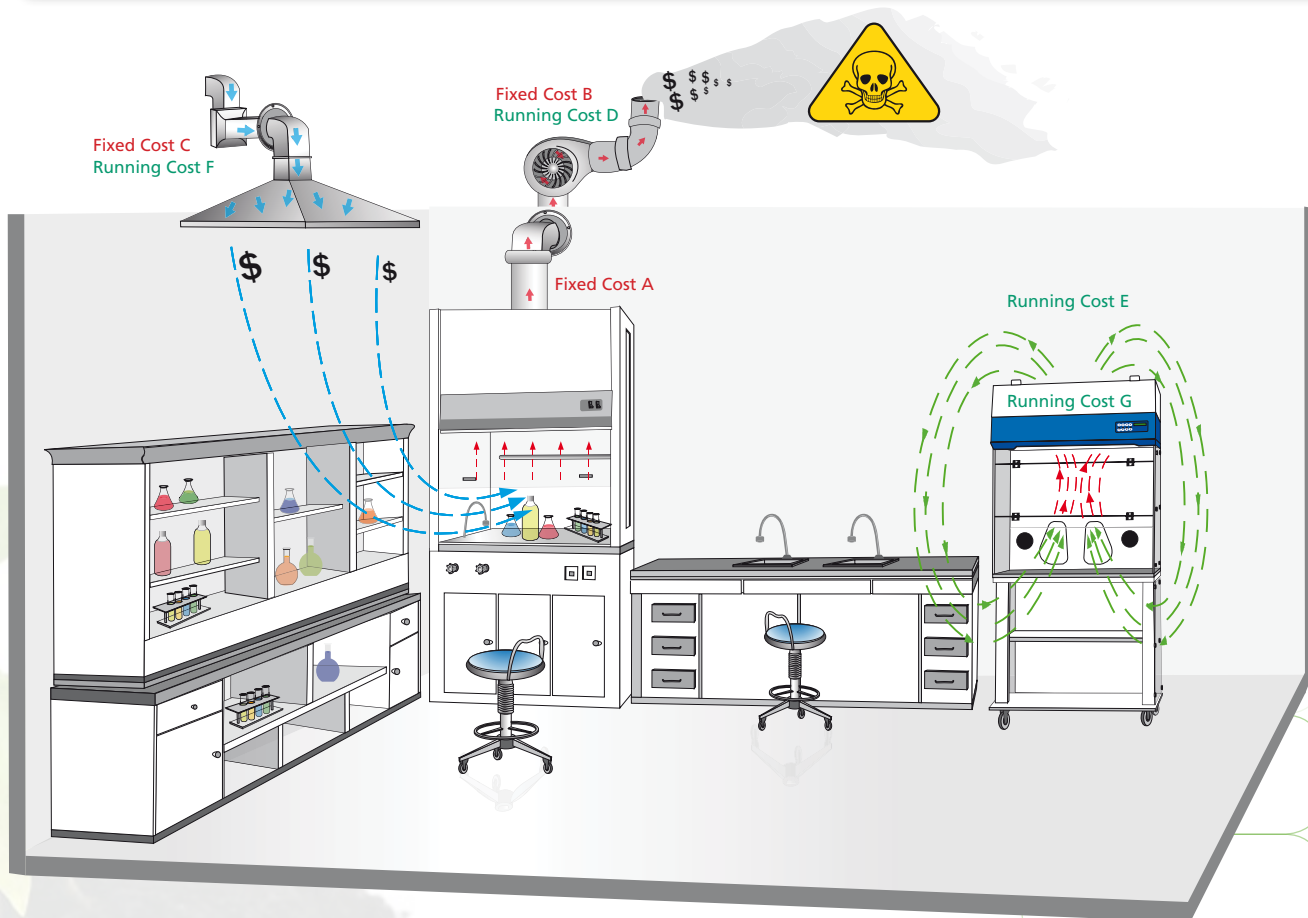

Note: Numerical figures are estimates based on US average weather conditions and commercial sector energy prices for a 6' (1.8 m) hood operating for 24 hrs a day at nominal hood opening and 100 fpm (0.5 m/s) face velocity. Figures provide a guide and differ in individual situations. (Evan Mills, Dale Sartor (2003), Energy use and savings potential for laboratory fume hoods).

# Ascent

Ductless Fume Hood • Ascent™ Max Ductless Fume Hoods and Ascent™ Opti Ductless Fume Hoods

Touchpad data entry buttons permit control settings and access to diagnostics, default settings and hierarchical menus.

Color coded indicator lamps display green for primary function (fan operation) and blue for secondary function (fluorescent lights and electrical outlet).

A graphical interface indicates hood performance.

Digital read-out with alpha-numeric display indicates all input, status and alarm functions.

All functions can be user activated through touch-pad programming access; see Operations Manual.



Sentinel Microprocessor Control System, Programmable

- When programmed ON
- the start-up sequence confirms status with Air Safe and local time display.
- the Personal Identification Number (PIN) access restricts unauthorized adjustments.
- an airflow alarm warns of deviations from normal velocities.

### Sentinel Microprocessor Control, Alarm, Monitoring System

Esco's Sentinel™ microprocessor-based hood control system supervises operation of all hood functions.

- Continuous monitoring of hood airflow is displayed on a bright, easy-to read LCD panel.
- Audible and visual alarms for low airflow and/or unsafe sash positions.
- Configurable post-purge cycle ensures all residue contaminants are purged out of the hood work zone before the hood is de-activated.
- An integrated, temperature-compensated, true airflow velocity sensor provides an accurate airflow reading despite room temperature fluctuation.

- All electronic parts are contained inside a plug-and-play module that permits easy exchange if required.
- Microprocessor software updates are available from Esco for download via the Internet.

Sentinel functions are factory set to default to ON or OFF, depending on worldwide destination and local preferences. Default settings can be user activated through the touchpad data entry access.

- Automatic start-up sequence will prepare the hood for normal operation and advise when safe conditions are established.
- An administrator controlled PIN (Personal Identification Number) can be set to restrict access to main menu.

- The airflow alarm can be activated or deactivated depending on user preference and nature of the work.
- Specially designed for use in ductless fume hoods, a blower meter helps the user monitor hood usage. Every 60 hours, the control system reminds the user to test the exhaust concentration with the appropriate gas detection tube to determine if the filter is saturated.

Consult your Esco Operating Manual or contact your Sales Representative for information on user-preference programming capabilities built into the Sentinel microprocessor platform.

### Computational Fluid Dynamics (CFD)

Computational fluid dynamics (CFD) modeling is employed in the development of Esco clean air and containment devices. The main thrusts are improved airflow uniformity, enhanced safety, reduction in noise levels and energy consumption.

For each model, engineering teams conceptualize possible designs. Instead

of building physical models for empirical testing, CFD models are used to simulate airflow patterns, pressurizations and possible areas of turbulence. This allows a large number of iterations to be rapidly developed and tested. Finally, physical prototypes are constructed, tested, and the best design is selected for production.

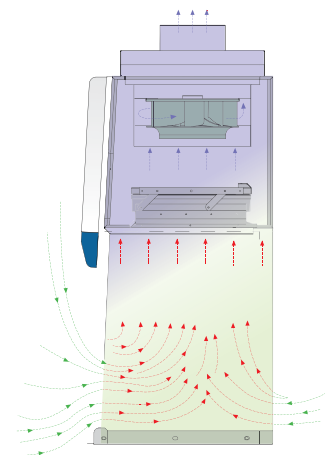

## General Applications for Ductless Fume Hoods

### Education

- Esco Ascent Ductless Fume Hoods are useful for secondary and post secondary education, science classes and in laboratories where activated carbon filtration offers safety from selected aerosols and vapours.
- Hoods are easily assembled, portable configured for high visibility to improve classroom participation
- Installation costs are minimal; no ducting required.

### Life Sciences

- Ductless fume hoods are ideal for protocols using small quantities of solvents.
- Depending on the solvents used, numerous vapour-generating laboratory processes such as HPLC preparation and biochemistry protocols can be performed with improved safety and comfort.

### Forensics

- Forensic laboratories frequently use sterilents and reservatives. Formaldehyde, often mixed with alcohols or phenols, is commonly used. OSHA has a specific standard for formaldehyde that stipulates initial and periodic monitoring, protective equipment and clothing, training and designating regulated areas among others.
- Common chemicals used:
  - formaldehyde
  - methyl methacrylate
  - ammonia

### Clinical/Hospital

- From the clinical laboratory to the pathology department, ductless fume hoods offer protection against small quantities of formalin vapours and other chemicals used in histopathology and other processes.

### Industrial/Commercial

- Industrial and commercial applications range from quality control in cosmetic production to photochemicals, solvent extraction, purification and other processes where fumes or vapours are generated.

### Cleanrooms

- Ductless fume hoods will not remove tempered air from the cleanroom. A secondary HEPA filter can be installed to prevent particles generated during the work process from being recirculated to the cleanroom.

### Other Examples of Applications:

- Touch Up Painting
- Microscopy
- Slide Preparation
- Histology
- Fingerprinting
- Dental Laboratory
- Spray Adhesives
- Solvent Cleaning

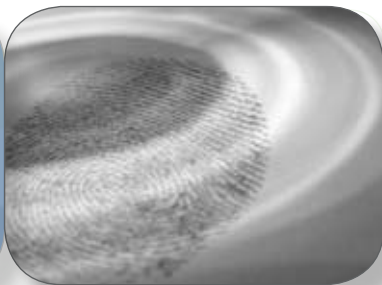

## Esco Ascent™ Ductless Fume Hoods Product Lineup

Model		Ascent Max™				Ascent Opti Basic™	Ascent Opti™	
Product Line		ADC-B_	ADC-C_	ADC-D_	ADC-E_	SPB-A_	SPD-A_	SPD-B_
VOC Sensor		Optional	Optional	Optional	Optional			
Secondary HEPA Exhaust Filter					✓			
Secondary Backup Carbon Filter			✓					
Control System		Sentinel Silver™ Microprocessor	Sentinel Silver™ Microprocessor	Sentinel Silver™ Microprocessor	Sentinel Silver™ Microprocessor	Rocker Switches	Sentinel Silver™ Microprocessor	Sentinel Silver™ Microprocessor
Hood Walls	Side Walls	Tempered Glass	Tempered Glass	Tempered Glass	Tempered Glass	Acrylic	Acrylic	Acrylic
	Rear Wall	Powder Coated EG Steel	Powder Coated EG Steel	Tempered Glass	Powder Coated EG Steel	Powder Coated EG Steel	Powder Coated EG Steel	Acrylic
Auto-Purge™ slots		✓	✓	✓	✓			
Sloped Front		3°	3°	3°	3°	13°	13°	13°
Sash Type		Vertical Sliding	Vertical Sliding	Vertical Sliding	Vertical Sliding	Hinged	Hinged	Hinged
Motorized Sash		Optional	Optional	Optional	Optional			
Airflow Alarm		✓	✓	✓	✓		✓	✓
Sound Emission		<61 dBA	<61 dBA	<61 dBA	<61 dBA	<62 dBA	<58 dBA	<58 dBA
Certification	ANSI/ASHRAE 110-1995, USA, Exposure Control Technologies, Invent UK	✓	✓	✓	✓	✓*	✓*	✓*
	BS 7989-2001, UK, Invent UK	✓	✓	✓	✓		✓	✓
	BS 7258, UK, Invent UK	✓	✓	✓	✓		✓	✓
	AFNOR NFX 15-203, France, Invent UK	✓	✓	✓	✓			
	EN-14175-3, Europe, Invent UK	✓	✓	✓	✓			
Warranty		5 years	5 years	5 years	5 years	3 years	3 years	3 years
Widths Available		0.6, 0.9, 1.2, 1.5 and 1.8 m (2', 3', 4', 5' and 6')	0.9, 1.2, 1.5 and 1.8 m (3', 4', 5' and 6')	0.9, 1.2, 1.5 and 1.8 m (3', 4', 5' and 6')	0.9, 1.2 and 1.5 m (3', 4' and 5')	0.6 m (2')	0.9 and 1.2 m (3' and 4')	0.9 and 1.2 m (3' and 4')
Shipping		Fully-assembled	Fully-assembled	Fully-assembled	Fully-assembled	Unassembled	Unassembled	Unassembled

\* Only certified by Invent UK.

# Esco Ascent™ Max Ductless Fume Hood

Provides Operator and Environmental Protection

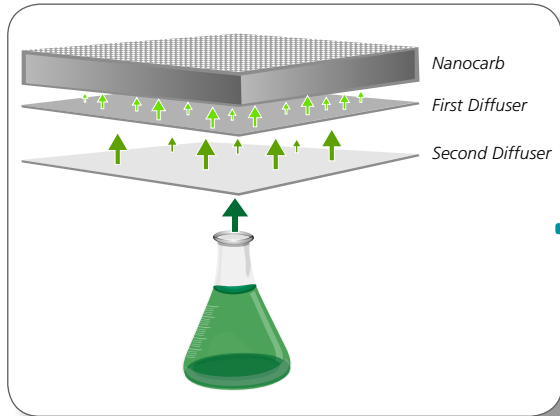

## Integrated Filtration System

- Esco Nanocarb™ Filters deliver extended filter capacity, high efficiency and long life.
- Industry exclusive dual diffuser design ensures uniform loading of filters and maximizes filter life.
- Possibility of secondary backup carbon filter or secondary backup HEPA filter.
- Filter ID window behind the front panel allows user to easily identify the type of filter in use.

10



## Easy Filter Change

Efficient perimeter clamping ensures no leakage as well as allows for easy filter change procedure.

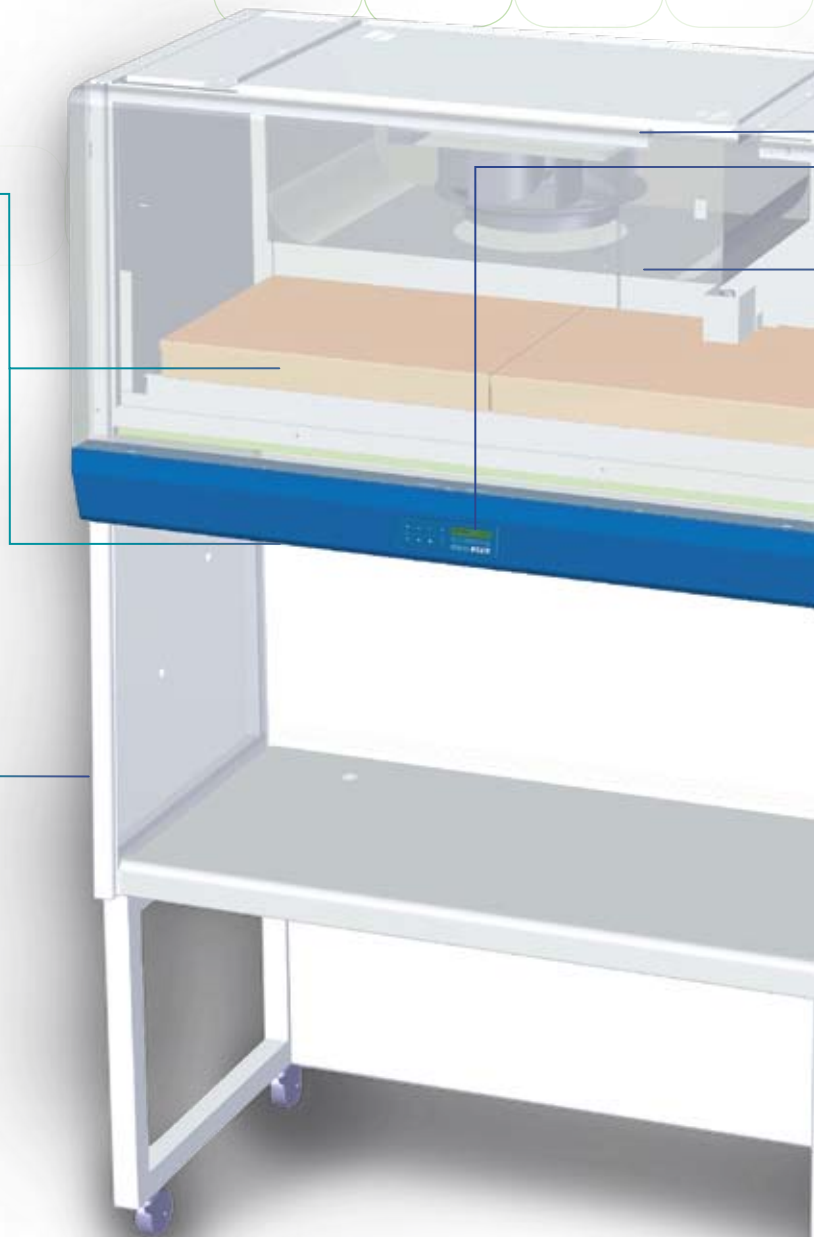

Ascent™ Max Ductless Fume Hood, Model ADC-4B\_  
Shown with SPC-4A0 (support stand with caster wheels).

	Chemical Fume Containment	Filter Efficiency	Electrical Safety
Standards Compliance	ANSI / ASHRAE 110-1995, USA BS 7258, UK AFNOR NF X 15-203, France EN14175.3, Europe	BS 7989 - 2001, UK AFNOR NF X 15-211, France	UL-C-61010-1, USA CAN/CSA-22.2, No.61010-1 EN-61010-1, Europe IEC61010-1, Worldwide

# Ascent

Ductless Fume Hood • Ascent™ Max Ductless Fume Hoods and Ascent™ Opti Ductless Fume Hoods

### Optional VOC Sensor



Detects presence of volatile organic compounds in the exhaust and alarms to indicate filter saturation.



### Sentinel Silver™ Microprocessor Control, Alarm System

Advanced microprocessor control supervises operation of all hood functions. Temperature-compensated air velocity sensor monitors both exhaust. 24-hour clock and blower run hour meter, are standard.



### Robust Hood Construction

Key components, including fluorescent lamps, motor capacitor, electrical harness, electronic ballast, and switch control are mounted outside the airstream and away from contaminated areas to permit easy service.

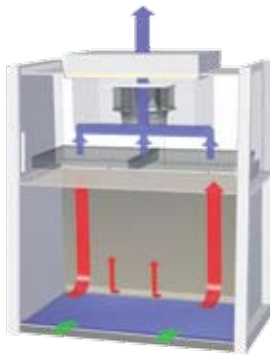

### Filtration System

The inflow flushes the entire work zone of the hood; within the main chamber of the hood, negative pressure (relative to the ambient environment) is maintained so that no chemical fumes or vapours escape the work zone.

## Key Features

- Certified containment - chemical vapors are contained within the enclosure and will not leak through the front opening.
- Auto-Purge™ slots at the back of the work zone improves containment and operator protection by preventing the accumulation of fumes in the work zone.
- Permanently lubricated direct drive centrifugal fan(s); energy efficient external rotor type design reduces operating costs; industry exclusive backward-curve motorised impeller design guarantees better airflow uniformity, lower noise and lower overall energy consumption.
- Built-in solid state variable speed controller(s) with built-in RFI and noise filters is superior to conventional "step" controllers.
- Esco **ISOCIDE™** antimicrobial surface on all painted surfaces minimizes surface contamination.
- Hood is shipped fully-assembled; simply plug the unit into a power source for operation
- Industrial-grade main body and dress panels constructed from electrogalvanised steel are durable.
- Ascent Max Ductless Fume Hoods are warranted for 5 years excluding consumable parts and accessories.

### Ascent Max™ Product Lineup

- **Standard (ADC-B\_)**
  - Standard Ascent Max™ Ductless Fume Hood
  - Available in 2', 3', 4' 5' and 6' widths.
- **Secondary Backup Carbon Filter (ADC-C\_)**
  - Secondary (backup) exhaust filter offers a higher filtration efficiency against toxic fumes.
  - When installed the hood complies with the requirements of ANSI/AIHA Z9.5-2003.
  - Available in 3', 4' 5' and 6' widths.
- **Transparent Back Wall (ADC-D\_)**
  - Transparent glass back wall for maximum visibility.
  - Ideal for classrooms and educational demonstrations.
  - Available in 3', 4', 5' and 6' widths.
- **Secondary Backup HEPA Filter (ADC-E\_)**
  - HEPA filter (H14) with efficiency of 99.99% at 0.3 microns is available in addition to carbon filter.
  - Suitable when the application involves the generation of biohazardous aerosols in the work zone.
  - Available in 3', 4' and 5' widths.

**Model ADC-2B\_ Ascent Max Ductless Fume Hood Technical Specification (0.6 m / 2' Width Model)**

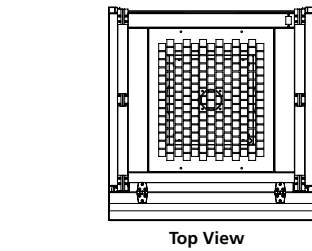

Top View

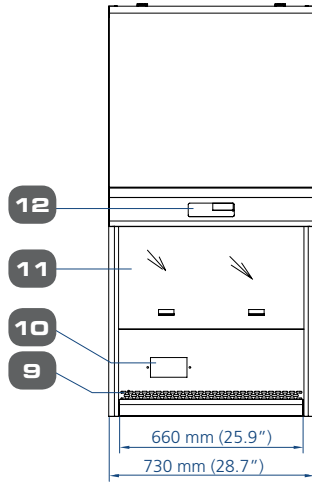

Front View

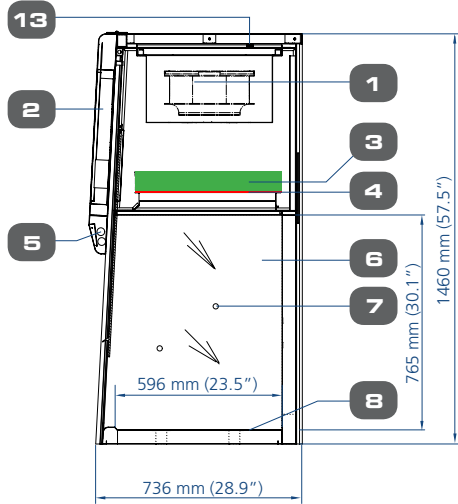

Side View

1. Fan
2. Electrical / electronics panel
3. Carbon filter(s)
4. Pre-filter
5. Fluorescent lamp
6. Tempered glass sides
7. Plussed service fixture provision (2 on each side)
8. Stainless steel worktop
9. AutoPurge™ slots
10. Electrical outlet Retrofit Kit™ provision
11. Tempered glass sliding sash window with counter balance
12. Esco Sentinel Silver microprocessor control system
13. VOC sensor (optional)

**Model ADC- B\_ & ADC- D\_ (with tempered glass backwall), Ascent Max Ductless Fume Hood Technical Specification (0.9 to 1.8 m / 3' to 6' Width Models)**

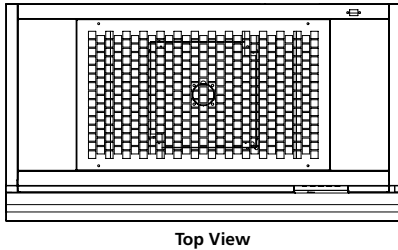

Top View

	A	B
ADC-3B_ / ADC-3D_	1035 mm (40.7")	965 mm (38.0")
ADC-4B_ / ADC-4D_	1340 mm (52.8")	1270 mm (50.0")
ADC-5B_ / ADC-5D_	1645 mm (64.8")	1575 mm (62.0")
ADC-6B_ / ADC-6D_	1950 mm (76.8")	1880 mm (74.0")

1. Fan
2. Electrical panel
3. Carbon filter(s)
4. Prefilter
5. Fluorescent lamp
6. Tempered glass sides
7. Plussed service fixture provision (2 on each side)
8. Stainless steel worktop
9. AutoPurge™ slots
10. Standard Esco electrical outlet Retrofit Kit™ provision
11. Tempered glass backwall (ADC- D\_ model)
12. Tempered glass sliding sash window
13. Esco Sentinel Silver microprocessor control system
14. VOC sensor (optional)

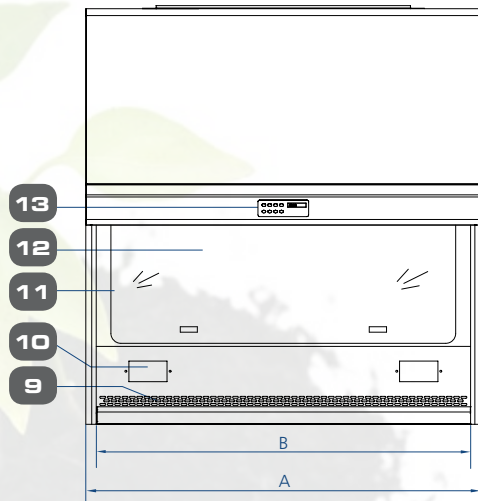

Front View

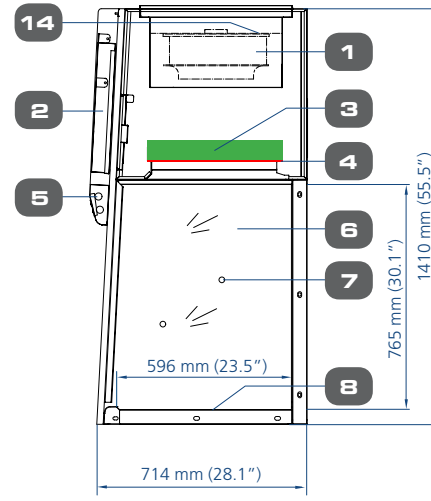

Side View

**Model ADC-C\_, Ascent Max Ductless Fume Hood Technical Specification (With Secondary Backup Carbon Filter)**

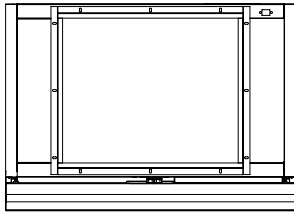

Top View

	A	B
ADC-3C_	1035 mm (40.7")	965 mm (38.0")
ADC-4C_	1340 mm (52.8")	1270 mm (50.0")
ADC-5C_	1645 mm (64.8")	1575 mm (62.0")
ADC-6C_	1950 mm (76.8")	1880 mm (74.0")

1. Fan
2. Electrical panel
3. Carbon filter (Code A)
4. Pre-filter
5. Flourescent lamps
6. Tempered glass sides
7. Plussed service fixture provision (2 on each side)
8. Stainless steel worktop
9. AutoPurge™ slots
10. Standard Esco electrical outlet Retrofit Kit™ provision
11. Tempered glass sliding sash window
12. Esco Sentinel Silver microprocessor control system
13. Back up carbon filter
14. VOC sensor (optional)

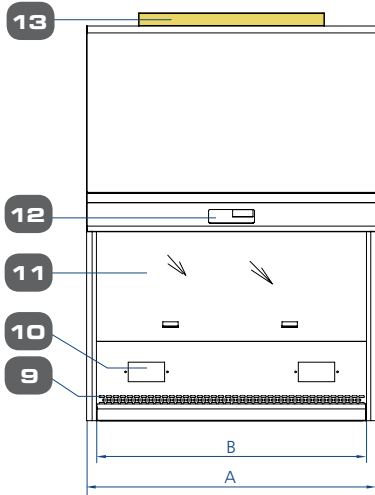

Front View

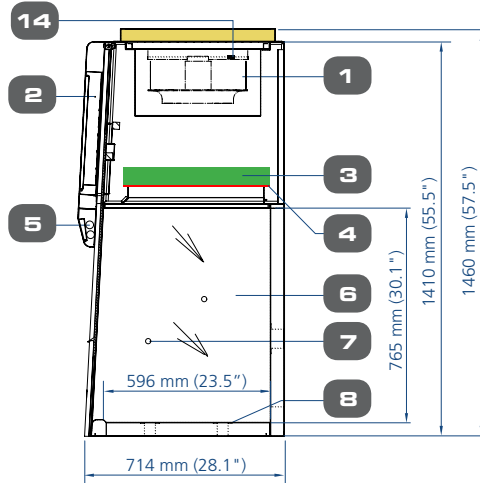

Side View

**Model ADC-E\_, Ascent Max Ductless Fume Hood Technical Specification (With Secondary Backup HEPA Filter)**

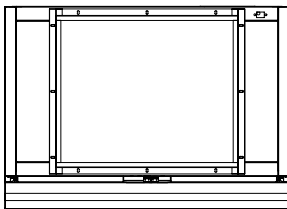

Top View

	A	B
ADC-3E_	1035 mm (40.7")	965 mm (38.0")
ADC-4E_	1340 mm (52.8")	1270 mm (50.0")
ADC-5E_	1645 mm (64.8")	1575 mm (62.0")

1. Fan
2. Electrical panel
3. Carbon filter (Code A)
4. Pre-filter
5. Flourescent lamp
6. Tempered glass sides
7. Plussed service fixture provision (2 on each side)
8. Stainless steel worktop
9. AutoPurge™ slots
10. Standard Esco electrical outlet Retrofit Kit™ provision
11. Tempered glass sliding sash window
12. Esco Sentinel Silver microprocessor control system
13. Back up HEPA Filter
14. VOC sensor (optional)

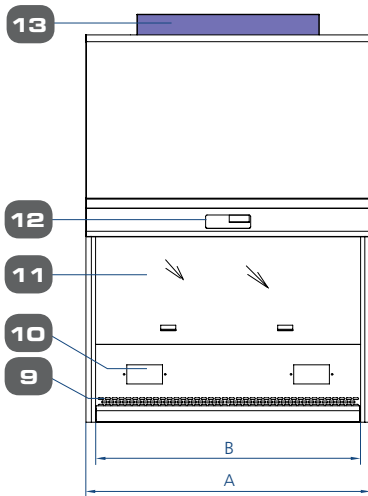

Front View

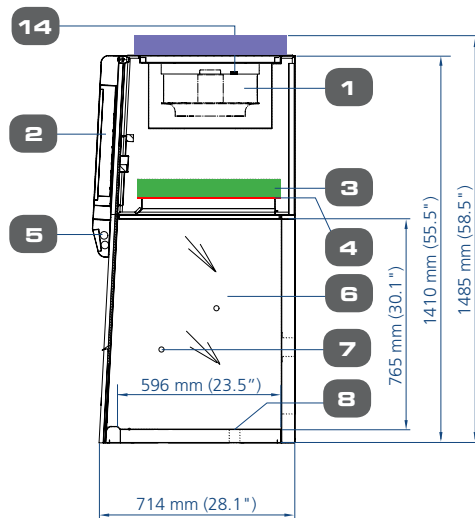

Side View

## General Specifications, Ascent™ Max Ductless Fume Hood (B and D-Series)

Model	ADC-2B_*	ADC-3_	ADC-4_	ADC-5_	ADC-6_	
Nominal Size	0.6 meters (2')	0.9 meters (3')	1.2 meters (4')	1.5 meters (5')	1.8 meters (6')	
External Dimensions (W x D x H)	730 x 735.5 x 1460 mm 28.7" x 28.9" x 57.5"	1035 x 714 x 1410 mm 40.7" x 28.1" x 55.5"	1340 x 714 x 1410 mm 52.8" x 28.1" x 55.5"	1645 x 714 x 1410 mm 64.8" x 28.1" x 55.5"	1950 x 714 x 1410 mm 76.8" x 28.1" x 55.5"	
Internal Work Area (W x D x H)	660 x 596 x 765 mm 30.0" x 23.5" x 30.1"	965 x 642 x 780 mm 40.7" x 25.3" x 30.7"	1268 x 642 x 780 mm 50.0" x 25.3" x 30.7"	1575 x 642 x 780 mm 64.8" x 25.3" x 30.7"	1880 x 642 x 780 mm 76.8" x 25.3" x 30.7"	
Standard Filtration Elements	Pre-filter	Disposable, non-washable polyester fibre, 85% arrestance, EU3 rated				
	Main filter	Activated carbon with granular media bed (7 different filter types available, codes A to G - refer to page 4 of this catalogue. State required filter type when ordering).				
Total Weight of Carbon in Main Filter	8.5 kg (18.7 lbs)	2 x (10.3 kg) each 2 x (22.7 lbs) each	2 x (13.9 kg) each 2 x (30.6 lbs) each	2 x (17.4 kg) each 2 x (38.3 lbs) each	3 x (13.9 kg) each 3 x (30.6 lbs) each	
Inflow Air Velocity	Initial setpoint: 0.40 m/s or 80 fpm					
Air Volume	238 m³/h (140 cfm)	347 m³/h (205 cfm)	457 m³/h (269 cfm)	567 m³/h (334 cfm)	677 m³/h (399 cfm)	
Sound Emission	55 dBA	55 dBA	57 dBA	58 dBA	58 dBA	
Fluorescent Light Intensity at Zero Ambient	>1000 Lux (>93 foot-candles)					
Hood Construction**	Main Body	1.2 mm (0.05") 18 gauge electro-galvanized steel with white oven-baked epoxy-polyester isocide antimicrobial powder coated finish				
	Back Wall	(B-Series) 1.2 mm (0.05") 18 gauge electrogalvanized steel with white oven-baked epoxy-polyester isocide antimicrobial powder coated finish				
		(D-Series*) Tempered glass				
	Side Walls	Tempered glass				
Work Top	1.5 mm (0.06") 16 gauge stainless steel, type 304, with 4B finish					
Electrical	220-240V, AC, 50Hz, 1Ø	ADC-2B1	ADC-3_1	ADC-4_1	ADC-5_1	ADC-6_1
	Maximum Power/ Amp	350W / 2A	350W / 2A	350W / 2A	550W / 3A	550W / 3A
	Outlet Maximum Amp	5A	5A	5A	5A	5A
	Total Amp	7A	7A	7A	8A	8A
	BTU/ Hr	714	714	714	1122	1122
	110-120V, AC, 60Hz, 1Ø	ADC-2B2	ADC-3_2	ADC-4_2	ADC-5_2	ADC-6_2
	Maximum Power/ Amp	350W / 3.5A	350W / 3.5A	385W / 3.5A	450W / 4A	500W / 4A
	Outlet Maximum Amp	5A	5A	5A	5A	5A
	Total Amp	8.5A	8.5A	8.5A	9A	9A
	BTU/ Hr	714	714	785	918	1020
	220-240V, AC, 60Hz, 1Ø	ADC-2B3	ADC-3_3	ADC-4_3	ADC-5_3	ADC-6_3
	Maximum Power/ Amp	350W / 2A	350W / 2A	350W / 2A	550W / 3A	550W / 3A
	Outlet Maximum Amp	5A	5A	5A	5A	5A
	Total Amp	7A	7A	7A	8A	8A
	BTU/ Hr	714	714	714	1122	1122
	110-120V, AC, 50Hz, 1Ø	ADC-2B4	ADC-3_4	ADC-4_4	ADC-5_4	ADC-6_4
	Maximum Power/ Amp	350W / 3.5A	350W / 3.5A	385W / 3.5A	450W / 4A	500W / 4A
	Outlet Maximum Amp	5A	5A	5A	5A	5A
	Total Amp	8.5A	8.5A	8.5A	9A	9A
	BTU/ Hr	714	714	785	918	1020
Net Weight**	130 kg (286 lbs)	175 kg (386 lbs)	225 kg (496 lbs)	245 kg (540 lbs)	293 kg (646 lbs)	
Shipping Weight**	150 kg (331 lbs)	205 kg (452 lbs)	261 kg (575 lbs)	300 kg (661 lbs)	339 kg (747 lbs)	
Shipping Dimensions, Maximum (W x D x H)**	800 x 820 x 1750 mm 31.5" x 32.3" x 68.9"	1130 x 840 x 1750 mm 44.5" x 33.0" x 68.9"	1410 x 840 x 1750 mm 55.5" x 33.0" x 68.9"	1730 x 840 x 1750 mm 68.1" x 33.0" x 68.9"	2050 x 840 x 1750 mm 80.7" x 33.0" x 68.9"	
Shipping Volume, Maximum**	1.58 m³ (55.6 cu.ft)	1.66 m³ (58.6 cu.ft)	2.07 m³ (73.1 cu.ft)	2.51 m³ (88.6 cu.ft)	3.01 m³ (106.3 cu.ft)	

\* D-Series not available in 0.6m (2') width.  
 \*\* Hood only, excludes optional stand.

## General Specifications, Ascent™ Max Ductless Fume Hood (C-Series)

Model	ADC-3C_	ADC-4C_	ADC-5C_	ADC-6C_	
Nominal Size	0.9 meters (3')	1.2 meters (4')	1.5 meters (5')	1.8 meters (6')	
External Dimensions (W x D x H)	1035 x 714 x 1460 mm 40.7" x 28.1" x 55.5"	1340 x 714 x 1460 mm 52.8" x 28.1" x 57.5"	1645 x 714 x 1460 mm 64.8" x 28.1" x 57.5"	1950 x 714 x 1460 mm 76.8" x 28.1" x 57.5"	
Internal Work Area (W x D x H)	965 x 642 x 780 mm 40.7" x 25.3" x 30.7"	1268 x 642 x 780 mm 50.0" x 25.3" x 30.7"	1575 x 642 x 780 mm 64.8" x 25.3" x 30.7"	1880 x 642 x 780 mm 76.8" x 25.3" x 30.7"	
Standard Filtration Elements	Pre-filter	Disposable, non-washable polyester fibre, 85% arrestance, EU3 rated			
	Main filter	Activated carbon with granular media bed (7 different filter types available, codes A to G - refer to page 4 of this catalogue. State required filter type when ordering).			
	Backup filter	Activated carbon with granular media bed (7 different filter types available, codes A to G - refer to page 4 of this catalogue. State required filter type when ordering).			
Total Weight of Carbon in Main Filter	2 x (10.3 kg) each 2 x (22.7 lbs) each	2 x (13.9 kg) each 2 x (30.6 lbs) each	2 x (17.4 kg) each 2 x (38.3 lbs) each	3 x (13.9 kg) each 3 x (30.6 lbs) each	
Inflow Air Velocity	Initial setpoint: 0.40 m/s or 80 fpm				
Air Volume	347 m³/h (205 cfm)	457 m³/h (269 cfm)	567 m³/h (334 cfm)	677 m³/h (399 cfm)	
Sound Emission	60 dBA	61 dBA	60 dBA	62 dBA	
Fluorescent Light Intensity at Zero Ambient	>1141 Lux (>106 foot-candles)	>1397 Lux (>130 foot-candles)	>1060 Lux (>99 foot-candles)	>1116 Lux (>104 foot-candles)	
Hood Construction	Main Body	1.2 mm (0.05") 18 gauge electro-galvanized steel with white oven-baked epoxy-polyester isocide antimicrobial powder coated finish			
	Side Walls	Tempered glass			
	Work Top	1.5 mm (0.06") 16 gauge stainless steel, type 304, with 4B finish			
Electrical	220-240V, AC, 50Hz, 1Ø	ADC-3C1	ADC-4C1	ADC-5C1	ADC-6C1
	Maximum Power/ Amp	350W / 2A	350W / 2A	550W / 3A	550W / 3A
	Outlet Maximum Amp	5A	5A	5A	5A
	Total Amp	7A	7A	8A	8A
	BTU/ Hr	714	714	1122	1122
	110-120V, AC, 60Hz, 1Ø	ADC-3C2	ADC-4C2	ADC-5C2	ADC-6C2
	Maximum Power/ Amp	350W / 3.5A	385W / 3.5A	450W / 4A	500W / 4A
	Outlet Maximum Amp	5A	5A	5A	5A
	Total Amp	8.5A	8.5A	9A	9A
	BTU/ Hr	714	785	918	1020
	220-240V, AC, 60Hz, 1Ø	ADC-3C3	ADC-4C3	ADC-5C3	ADC-6C3
	Maximum Power/ Amp	350W / 2A	350W / 2A	550W / 3A	550W / 3A
	Outlet Maximum Amp	5A	5A	5A	5A
	Total Amp	7A	7A	8A	8A
	BTU/ Hr	714	714	1122	1122
	110-120V, AC, 50Hz, 1Ø	ADC-3C4	ADC-4C4	ADC-5C4	ADC-6C4
	Maximum Power/ Amp	350W / 3.5A	385W / 3.5A	450W / 4A	500W / 4A
	Outlet Maximum Amp	5A	5A	5A	5A
	Total Amp	8.5A	8.5A	9A	9A
	BTU/ Hr	714	785	918	1020
Net Weight*	175 kg (386 lbs)	225 kg (496 lbs)	245 kg (540 lbs)	293 kg (646 lbs)	
Shipping Weight*	205 kg (452 lbs)	261 kg (575 lbs)	300 kg (661 lbs)	339 kg (747 lbs)	
Shipping Dimensions, Maximum (W x D x H)*	1130 x 840 x 1750 mm 44.5" x 33.0" x 68.9"	1410 x 840 x 1750 mm 55.5" x 33.0" x 68.9"	1730 x 840 x 1750 mm 68.1" x 33.0" x 68.9"	2050 x 840 x 1750 mm 80.7" x 33.0" x 68.9"	
Shipping Volume, Maximum*	1.66 m³ (58.6 cu.ft)	2.07 m³ (73.1 cu.ft)	2.51 m³ (88.6 cu.ft)	3.01 m³ (106.3 cu.ft)	

\* Hood only, excludes optional stand.

## General Specifications, Ascent™ Max Ductless Fume Hood (E-Series)

Model		ADC-3E <sub>—</sub>	ADC-4E <sub>—</sub>	ADC-5E <sub>—</sub>
Nominal Size		0.9 meters (3')	1.2 meters (4')	1.5 meters (5')
External Dimensions (W x D x H)		1035 x 714 x 1485 mm 40.7" x 28.1" x 58.5"	1340 x 714 x 1485 mm 52.8" x 28.1" x 58.5"	1645 x 714 x 1485 mm 64.8" x 28.1" x 58.5"
Internal Work Area (W x D x H)		965 x 642 x 780 mm 40.7" x 25.3" x 30.7"	1268 x 642 x 780 mm 50.0" x 25.3" x 30.7"	1575 x 642 x 780 mm 64.8" x 25.3" x 30.7"
Standard Filtration Elements	Pre-filter	Disposable, non-washable polyester fibre, 85% arrestance, EU3 rated		
	Main filter	Activated carbon with granular media bed <i>(7 different filter types available, codes A to G - refer to page 4 of this catalogue. State required filter type when ordering).</i>		
	Backup filter	HEPA filter, typical efficiency of 99.99%, removes particulates and aerosols		
Total Weight of Carbon in Main Filter		2 x (10.3 kg) each 2 x (22.7 lbs) each	2 x (13.9 kg) each 2 x (30.6 lbs) each	2 x (17.4 kg) each 2 x (38.3 lbs) each
Inflow Air Velocity		Initial setpoint: 0.40 m/s or 80 fpm		
Air Volume		347 m <sup>3</sup> /h (205 cfm)	457 m <sup>3</sup> /h (269 cfm)	567 m <sup>3</sup> /h (334 cfm)
Sound Emission		61 dBA	62 dBA	62 dBA
Fluorescent Light Intensity at Zero Ambient		>1115 Lux (>104 foot-candles)	>1107 Lux (>103 foot-candles)	>1082 Lux (>101 foot-candles)
Hood Construction	Main Body and Back Wall	1.2mm (0.06") 18 gauge electro-galvanised steel with white oven-baked epoxy-polyester powder-coated finish		
	Side Walls	Tempered glass		
	Work Top	1.5 mm (0.06") 16 gauge stainless steel, type 304, with 4B finish		
Electrical	220-240V, AC, 50Hz, 1Ø	ADC-3E1	ADC-4E1	ADC-5E1
	Maximum Power/ Amp	350W / 2A	350W / 2A	550W / 3A
	Outlet Maximum Amp	5A	5A	5A
	Total Amp	7A	7A	8A
	BTU/ Hr	714	714	1122
	110-120V, AC, 60Hz, 1Ø	ADC-3E2	ADC-4E2	ADC-5E2
	Maximum Power/ Amp	350W / 3.5A	385W / 3.5A	450W / 4A
	Outlet Maximum Amp	5A	5A	5A
	Total Amp	8.5A	8.5A	9A
	BTU/ Hr	714	785	918
	220-240V, AC, 60Hz, 1Ø	ADC-3E3	ADC-4E3	ADC-5E3
	Maximum Power/ Amp	350W / 2A	350W / 2A	550W / 3A
	Outlet Maximum Amp	5A	5A	5A
	Total Amp	7A	7A	8A
	BTU/ Hr	714	714	1122
	110-120V, AC, 50Hz, 1Ø	ADC-3E4	ADC-4E4	ADC-5E4
	Maximum Power/ Amp	350W / 3.5A	385W / 3.5A	450W / 4A
	Outlet Maximum Amp	5A	5A	5A
	Total Amp	8.5A	8.5A	9A
	BTU/ Hr	714	785	918
Net Weight*		175 kg (386 lbs)	225 kg (496 lbs)	245 kg (540 lbs)
Shipping Weight*		205 kg (452 lbs)	261 kg (575 lbs)	300 kg (745 lbs)
Shipping Dimensions, Maximum (W x D x H)*		1130 x 840 x 1750 mm 44.5" x 33.0" x 68.9"	1410 x 840 x 1750 mm 55.5" x 33.0" x 68.9"	1730 x 840 x 1750 mm 68.1" x 33.0" x 68.9"
Shipping Volume, Maximum*		1.66 m <sup>3</sup> (58.6 cu.ft)	2.07 m <sup>3</sup> (73.1 cu.ft)	2.51 m <sup>3</sup> (88.6 cu.ft)

\* Hood only, excludes optional stand.

## Options & Accessories

### Support Stands

- **Support Stand with Castor Wheels (SPC)**



- Available in two standard heights: 711mm (28.0") or 860mm (34.0")
- Durable polyurethane castor wheels with 360 degree horizontal rotation
- Brake system on front wheels
- Maximum weight supported: 600 kg (1323 lbs)

- **Support Stand with Levelling Feet (SAL)**



- Available in two standard sizes: 737 mm (29.0") or 838 mm (33.0"), ±38.1 mm (1.5")
- Maximum weight supported: 500 kg (1100 lbs)

- **Telescoping Support Stand (STL)**



- Adjustable height range: 660mm to 960mm (26.0" to 37.8")
- Adjustable in 25.4 mm (1.0") increments
- Maximum weight supported: 600 kg (1323 lbs)

- **Motorized Hydraulic Adjustable Support Stand (SPM)**



- Adjustable height range: 711 mm to 863 mm (28.0" to 34.0")
- With leveling feet or casters
- Maximum weight supported: 500 kg (1100 lbs)

### Electrical Outlets and Utility Fittings

- **Electrical Outlets**



- Powder-coated panel-mounted single electrical outlet.
- Available in all international socket outlet types. Specify when ordering.
- May be field installed.

- **VOC Sensor**

- Optional VOC Sensor may be installed to monitor the chemical concentration at the hood exhaust.
- The microprocessor control will activate audible / visual alarms if high concentration of chemical vapors are detected.
- Factory installed; specify when ordering

- **Factory-Installed Service Fixtures**



- Polypropylene drip-cup sink.
- Epoxy coated swan-neck faucet manufactured according to BS 2874, DIN 12898, DIN 12919 and DIN 3537.
- Factory installed; specify when ordering

- **Retrofit Kit™ Service Fixtures**



- Service fixtures for air / water / vacuum / gas.
- Manufactured according to DIN 12898, DIN 12919 and DIN 3537.
- May be field installed.

### Other Options and Accessories

- **Base Cabinet with Castor Wheels (BCC)**

- Maximizes storage space in the laboratory; convenient for solvents, acids and other laboratory chemicals.
- Includes an adjustable white powder-coated steel shelf
- Industrial-grade support structure constructed of electro-galvanised steel and abrasion resistant ovenbaked powder-coated finish
- Durable polyurethane castor wheels with 360 degree horizontal rotation
- Brake system on front wheels
- Maximum weight supported: 600kg (1323 lbs)

# Esco Ascent Opti™ Ductless Fume Hood

Provides Operator and Environment Protection



Sampling Port

## Easy Filter Change

Esco Nanocarb Filters ensure maximum filter efficiency as well as maximum filter capacity and therefore filter life. Simple hinged head unit allows for convenient on-site filter change.



## Work Top

The spill-retaining work top design with a recessed central area contains accidental liquid spills.

18

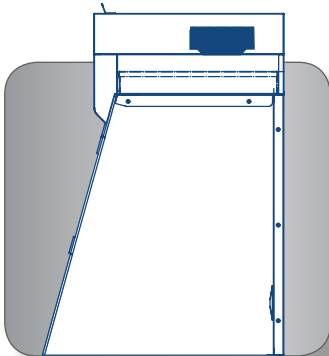

## Comfortable Ergonomic Design

13° degree sloped front allows easy access to work zone - enhancing ergonomics, eliminating operator fatigue and increasing productivity.



## Industry Exclusive Baffle Design

Integrating our experience with conventional fume hoods, Esco engineers designed a unique baffle for Ascent Opti™ Ductless Fume Hoods to improve containment and ensure the efficient removal of chemical fumes from the work zone.

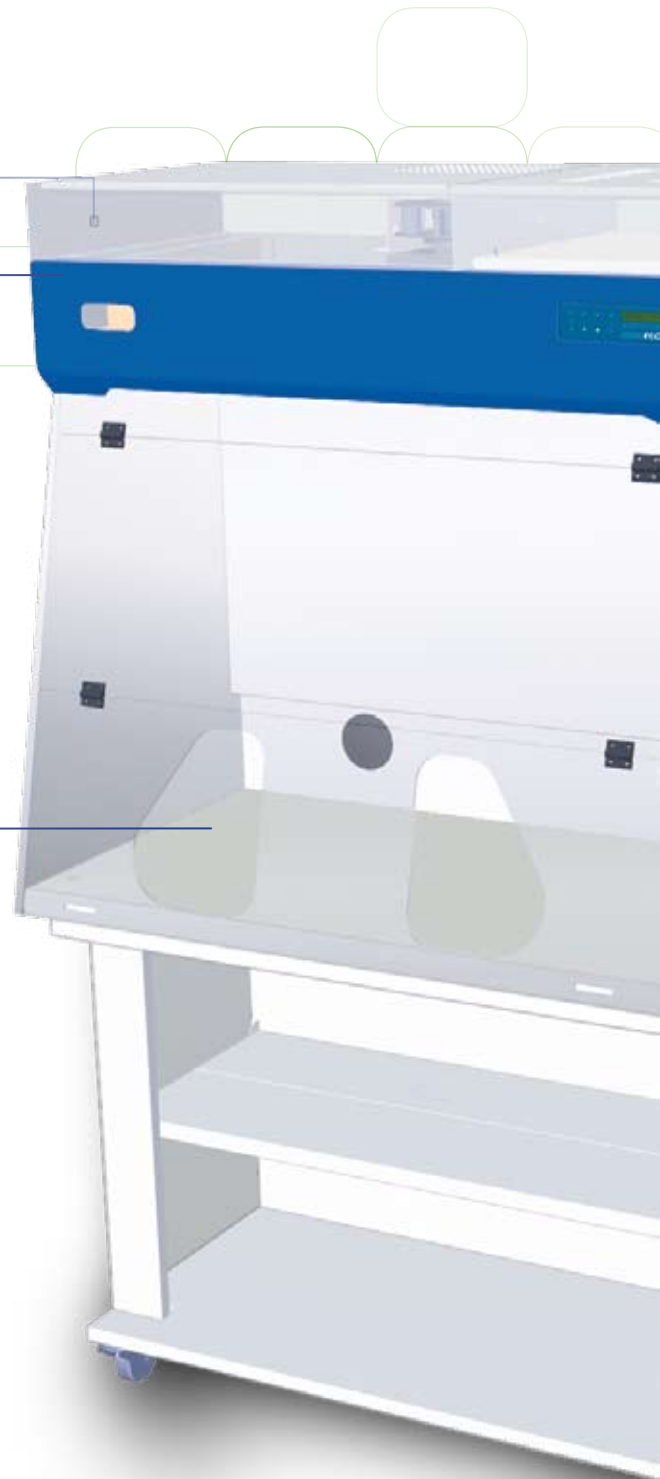

Ascent™ Opti Ductless Fume Hood, Model SPD-4A...  
Shown with optional MBC-4A0 (mobile cart).

Standards Compliance	Chemical Fume Containment	Filter Efficiency	Electrical Safety
	ANSI / ASHRAE 110-1995, USA BS 7258, UK EN14175.3, Europe	BS 7989 - 2001, UK AFNOR NF X 15-211, France	UL-C-61010A-1, USA CAN/CSA-22.2, No.61010-1 EN-61010-1, Europe IEC61010-1, Worldwide

# Ascent

Ductless Fume Hood • Ascent™ Max Ductless Fume Hoods and Ascent™ Opti Ductless Fume Hoods



### Sentinel Silver™ Microprocessor Control, Alarm System

Advanced microprocessor control supervises operation of all hood functions. Temperature-compensated air velocity sensor monitors airflow. 24-hour clock and blower run hour meter, are standard.

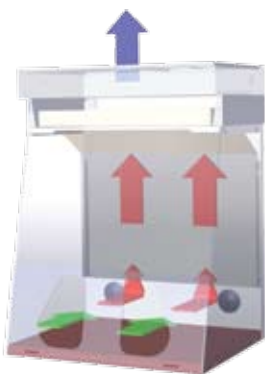

### Filtration System

The inflow flushes the entire work zone of the hood; within the main chamber of the hood, negative pressure (relative to the ambient environment) is maintained so that no chemical fumes or vapours escape the work zone.

### Ascent Opti™ Product Lineup



- **Standard (SPD\_ A\_)**
  - Standard Ascent Opti™ Ductless Fume Hood
- **Transparent Rear Wall (SPD\_ B\_)**
  - Ideal for classrooms and educational demonstrations

### Accessories



#### Mobile Cart (MBC-3A0, MBC-4A0)

- Optional mobile cart for placement of Ascent Opti
- Dimensions (W x D x H):
  - MBC-3A0: 845 x 700 x 800 mm  
31.5" x 27.6" x 31.5"
  - MBC-4A0: 1145 x 700 x 800 mm  
45.0" x 27.6" x 31.5"
- It has foldable trays to accommodate storage of large equipments
- Ships unassembled

## Key Features

- Better airflow uniformity and distribution within the hood for better operator protection.
- Certified containment - chemical vapors are contained within the enclosure and will not leak through the front opening.
- Permanently lubricated direct drive centrifugal fan(s); energy efficient external rotor motor type design reduces operating costs; extremely low noise and vibration levels due to proprietary construction and mounting technology.
- Built-in solid state variable speed controller(s) with built-in RFI and noise filters is superior to conventional "step" controllers.
- Industrial-grade main body constructed of electrogalvanised steel: with an abrasion-resistant white oven-baked powder-coated finish.
- Esco **ISOCIDE™** antimicrobial surface on all painted surfaces minimizes surface contamination.
- Transparent frameless acrylic front window and sides provide a high degree of visibility and operator comfort; front window is mounted on self-supporting pre-tensioned hinges, allowing for easy access during hood loading and startup.
- Ergonomic oval-shaped apertures for hands in the front window allows for maximum reach within the work zone while providing the operator with extra protection from any possible chemical spillage.
- Removable stainless steel work surface.
- Ascent Opti Ductless Fume Hoods are warranted for 3 years excluding consumable parts and accessories.
- Hood ships unassembled. On-site assembly can be completed in 60 minutes without special tools.

## Model SPB, Ascent Opti Basic Ductless Fume Hood Technical Specification (0.6 m / 2' Width Model)

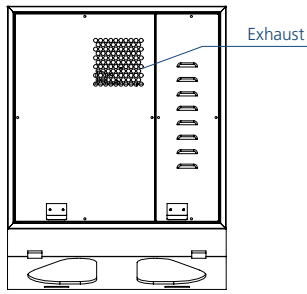

Exhaust

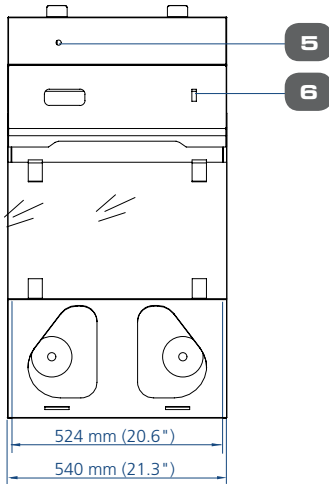

524 mm (20.6")

540 mm (21.3")

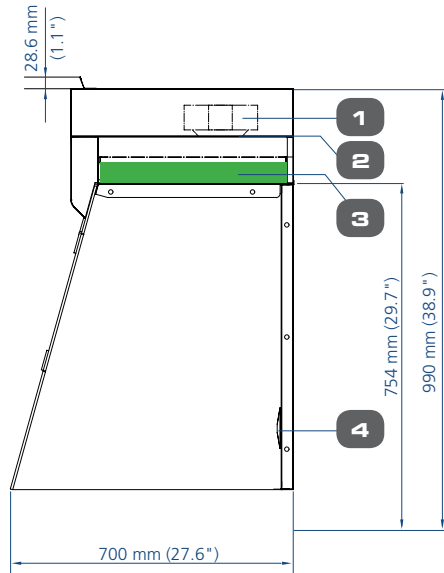

28.6 mm (1.1")

1

2

3

4

754 mm (29.7")

990 mm (38.9")

700 mm (27.6")

1. Fan
2. Electrical panel
3. Activated carbon filter
4. Pass-through ports for electrical or service connections
5. Test port
6. Blower switch

Note: SPB is a basic benchtop unit that does not come with microprocessor control, worktop, internal lighting and internal baffles.

## Model SPD, Ascent Opti Ductless Fume Hood Technical Specification (0.9 to 1.2 m / 3' to 4' Width Models)

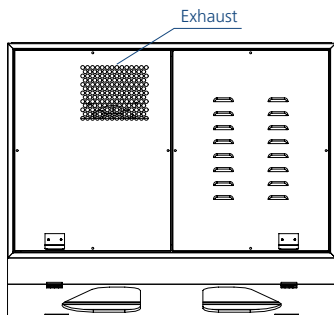

Exhaust

	A	B
SPD-3A_	840 mm (33.1")	820 mm (32.3")
SPD-4A_	1140 mm (44.9")	1116 mm (43.9")

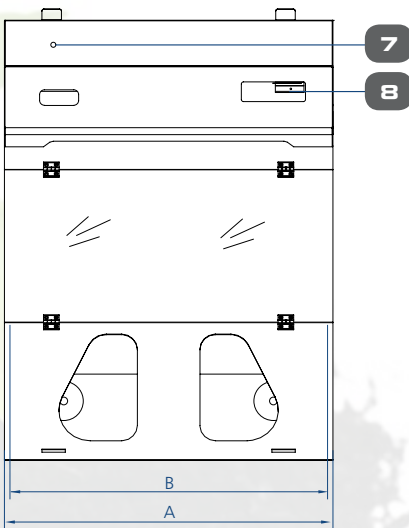

7

8

B

A

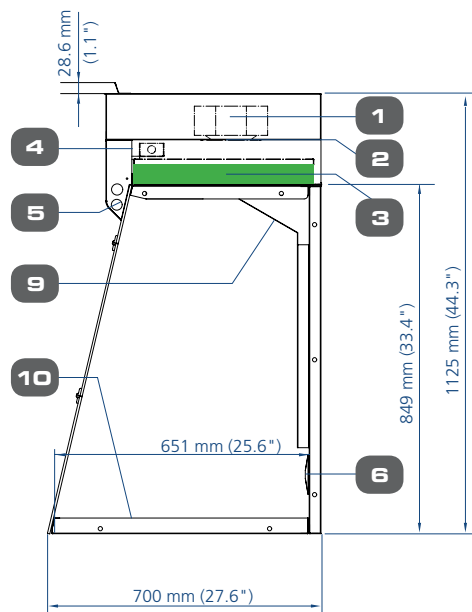

28.6 mm (1.1")

4

5

9

10

1

2

3

6

849 mm (33.4")

1125 mm (44.3")

700 mm (27.6")

1. Fan
2. Electrical panel
3. Activated carbon filter
4. Airflow sensor
5. Fluorescent lamp
6. Pass-through ports for electrical or service connections
7. Test port
8. Esco Sentinel Silver microprocessor control system
9. Baffle
10. Stainless steel worktop

## General Specifications, Ascent™ Opti Ductless Fume Hood

Model		SPB-2A_	SPD-3A/B_	SPD-4A/B_
Nominal Size		0.6 meters (2')	0.9 meters (3')	1.2 meters (4')
External Dimensions (W x D x H)		542 x 700 x 990 mm 21.3" x 27.6" x 39.0"	840 x 700 x 1125 mm 33.1" x 27.6" x 44.3"	1140 x 700 x 1125 mm 44.9" x 27.6" x 44.3"
Internal Work Area (W x D x H)		526 x 663 x 755 mm 20.7" x 26.1" x 29.7"	820 x 651 x 855 mm 32.3" x 25.6" x 33.7"	1116 x 651 x 855 mm 43.9 x 25.6" x 33.7"
Inflow Air Velocity Initial setpoint: average of 0.5 m/s or 100 fpm measured in plane of work aperture				
Air Volume		173 m³/h (102 cfm)	234 m³/h (138 cfm)	
Standard Filtration Elements	Main filter	Activated carbon with granular media bed (7 different filter types available - refer to page 4 of this catalogue. State required filter type when ordering).		
	Pre-filter	Disposable, non-washable polyester fibre, 85% arrestance, EU3 rated		
Total Weight of Carbon Filter		9.1 kg (20.1 lbs)	15.4 kg (34 lbs)	2 x (9.1 kg) each 2 x (20.1 lbs) each
Sound Emission		<62 dBA	<58 dBA at initial blower speed setting measured at typical operator work position	
Fluorescent Light Intensity		No Light	>350 lux / >28 foot candles at work surface level	
Controller		On/ Off Switches	Esco Sentinel Microprocessor Control	
Hood Construction	Main Body	1.2 mm (0.05") 18 gauge electrogalvanized steel with white oven-baked epoxy-polyester Isocide antimicrobial powder coated finish		
	Front Window	6 mm (0.2") Acrylic		
	Side Walls	9.5 mm (0.37") Acrylic		
	Back Walls	1.2 mm (0.05") 18 gauge electrogalvanized steel with white oven-baked epoxy-polyester Isocide antimicrobial powder coated finish	6 mm (0.2") Acrylic	
	Work Top	None (easy adaptability to any work surface)	1.5 mm (0.06") 16 gauge stainless steel, type 304, with 4B finish	
Electrical	220-240V, AC, 50Hz, 1Ø	SPB-2A1	SPD-3A1/ SPD-3B1	SPD-4A1/ SPD-4B1
	Maximum Power/ Amp	70W / 0.5A	110W / 0.5A	110W / 0.5A
	Total Amp	0.5A	0.5A	0.5A
	BTU/ Hr	239	375	375
	110-120V, AC, 60Hz, 1Ø	SPB-2A2	SPD-3A2/ SPD-3B2	SPD-4A2/ SPD-4B2
	Maximum Power/ Amp	75W / 0.5A	140W / 1.2A	170W / 1.5A
	Total Amp	0.5A	1.2A	1.5A
	BTU/ Hr	256	478	580
	220-240V, AC, 60HZ, 1Ø	SPB-2A3	SPD-3A3/ SPD-3B3	SPD-4A3/ SPD-4B3
	Maximum Power/ Amp	70W / 0.5A	110W / 0.5A	110W / 0.5A
	Total Amp	0.5A	0.5A	0.5A
	BTU/ Hr	239	375	375
Net Weight*		66 kg (145 lbs)	86 kg (181 lbs)	105 kg (231 lbs)
Shipping Weight*		70 kg (154 lbs)	114 kg (251 lbs)	160 kg (353 lbs)
Shipping Dimensions, Maximum (W x D x H)*		1000 x 800 x 1280 mm 39.3" x 31.5" x 50.4"	1060 x 1000 x 1100 mm 41.7" x 39.8" x 43.3"	1250 x 1250 x 1250 mm 49.2" x 49.2" x 49.2"
Shipping Volume, Maximum*		1.02 m³ (36 cu.ft)	1.17 m³ (41.3 cu.ft)	1.95 m³ (68.9 cu.ft)

\* Hood only, excludes optional stand.

## Nanocarb™ Filter for Ascent Opti Ductless Fume Hoods

*Filters are not included with new hoods and must be ordered separately. Filters are factory installed and tested.*

	Hood Model	Filter Quantity	Filter Item Code
Main Filter Used	SPB-2A_	1	CF_-4
	SPD-3A/B_	1	CF_-6
	SPD-4A/B_	2	CF_-4

# Esco Powdermax<sup>®</sup> Powder Weighing Balance Enclosure

Provides Operator and Environment Protection

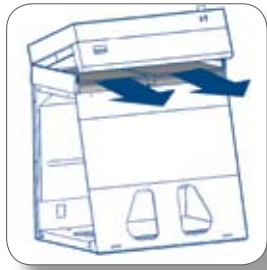

### Easy Filter Change

Filters are easily replaced from the front of the hood.

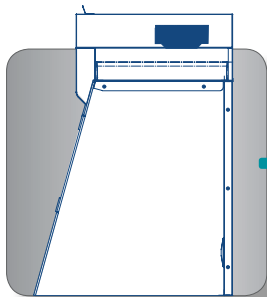

22

### Comfortable Ergonomic Design

13° degree sloped front allows easy access to work zone - enhancing ergonomics, eliminating operator fatigue and increasing productivity.



### Sentinel Silver™ Microprocessor Control, Alarm System

Advanced microprocessor control supervises operation of all hood functions. Temperature-compensated air velocity sensor monitors both exhaust. 24-hour clock and blower run hour meter, are standard.

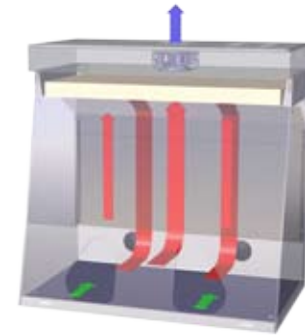

### Filtration System

The inflow flushes the work zone of the hood, negative pressure is maintained (relative to the ambient environment) so that no powders escape the work zone.

*Powdermax™ Powder Weighing Balance Enclosure, Model PW1-3A\_ Shown with optional MBC-3A0 (mobile cart).*

*Note: Esco Powdermax 1 Powder Weighing Balance Enclosure's unique design maintains balance stability to 4 decimal places without compromising containment.*

## General Specifications, Esco Powdermax Powder Weighing Balance Enclosure, Model PW1-3A\_

External Dimensions (W x D x H)	840 x 700 x 1125 mm (33.0" x 27.6" x 44.3")	
Internal Work Area, Dimensions (W x D x H)	820 x 650 x 848 mm (32.3" x 25.6" x 33.5")	
Air Volume	234 m <sup>3</sup> /h (138 cfm)	
Inflow Velocity	Initial setpoint: average of 0.5 m/s (100 fpm) measured in plane of work aperture	
HEPA Filter Efficiency	>99.99% at 0.3 microns	
Sound Emission	<55 dBA at initial blower speed setting measured at typical operator work position	
Fluorescent Lamp Intensity at Zero Ambient	>560 Lux (> 52 foot-candles)	
Electrical	<b>Model</b>	<b>Voltage</b>
	PW1-3A1	220-240V, AC, 50Hz, 1Ø
	PW1-3A2	110-120V, AC, 60Hz, 1Ø
	PW1-3A3	220-240V, AC, 60Hz, 1Ø

# Ascent

Ductless Fume Hood • Ascent™ Max Ductless Fume Hoods and Ascent™ Opti Ductless Fume Hoods

## FiltraCheck™ Application Advisory Service?

- Customers who intend to purchase a ductless fume hood but are unsure whether the ductless hoods are suitable for their application, can forward a list of chemicals that they will be handling and their pattern of usage to Esco's FiltraCheck service team.
- Document can be either forwarded by email or by fax to Esco.
- After careful analysis of the information provided, a written advisory will be generated and provided to the customer.
- This document will recommend the appropriate type of hood; ducted fume hood or ductless fume hood or neither based on the investigation.
- Depending on the type of chemicals used, the document may also contain a list of procedures, warnings, etc that will help in ensuring a safer laboratory working environment.

Note: Online Filtracheck form now available at <http://www.escoglobal.com/ductless/filtracheck.php>

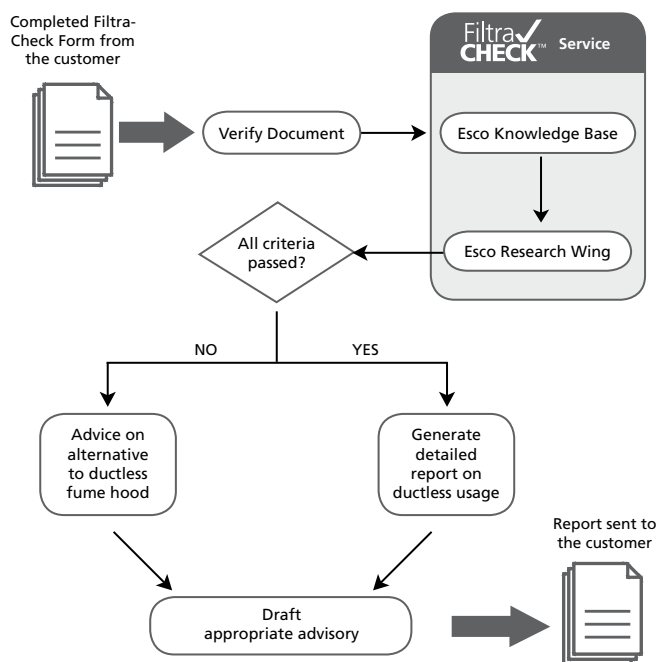

### FiltraCheck™ Form Informative Notes

<b>I</b>	The name of the chemical used in the ductless fume hood e.g. Toluene.
<b>II</b>	The extent to which the chemical has been diluted (in %).
<b>III</b>	Type of container used to hold the chemical e.g. plate, beaker etc.
<b>IV</b>	Surface area through which the chemical can evaporate.
<b>V</b>	Mention whether the process is being carried out open or covered.
<b>VI</b>	Provide more details on the type or nature of the work / process being carried out e.g. distillation, transfer etc.
<b>VII</b>	The temperature at which the work / process is being carried out. This is specially important in case the process requires the chemical to be heated.
<b>VIII</b>	Mention how frequently the concerned work / process is carried out.
<b>IX</b>	Quantity of chemical (in ml. or gm.) used during the process.
<b>X</b>	Time taken for carrying out the process.

Kindly fill up and return to us the following form in order for us to assess the compatibility of your application with Esco ductless fume hoods. Refer to the next page for more details on the information that has been sought under the various columns.

ESCO® FILTRACHECK™ FORM										
Chemical			Container			Handling				
No	Name	Dilution (%)	Type	Surface Area of Evaporation	Open or Covered	Type of Work	Temperature of Handling	Frequency of Work Per Day (PD) Per Week (PW) Per Month (PM)	Quantity of Chemical Used (ml. or gm.) Each Time	Duration of Handling (mins. or hrs.) Each Time
Ref	<b>I</b>	<b>II</b>	<b>III</b>	<b>IV</b>	<b>V</b>	<b>VI</b>	<b>VII</b>	<b>VIII</b>	<b>IX</b>	<b>X</b>
1										
2										
3										
4										
5										
6										
7										
8										
Comments: _____										
Name: _____										
Company/Institution: _____										
Address: _____										
_____										
_____ City: _____ Country: _____										
Tel: _____ Fax: _____										
Email: _____										
_____										

## Carbon Filter

Main Filter		
Hood Model	Filter Quantity	Filter Item Code
ADC-2B_	1	CF_-1
ADC-3B_	2	CF_-1
ADC-4B_	2	CF_-2
ADC-5B_	2	CF_-3
ADC-6B_	3	CF_-2
ADC-3C_	2	CF_-1
ADC-4C_	2	CF_-2
ADC-5C_	2	CF_-3
ADC-6C_	3	CF_-2
ADC-3D_	2	CF_-1
ADC-4D_	2	CF_-2
ADC-5D_	2	CF_-3
ADC-6D_	3	CF_-2
ADC-3E_	2	CF_-1
ADC-4E_	2	CF_-2
ADC-5E_	2	CF_-3
SPB-2A_	1	CF_-4
SPD-3A_	1	CF_-6
SPD-4A_	2	CF_-4
SPD-3B_	1	CF_-6
SPD-4B_	2	CF_-4

Secondary Backup Filter		
Hood Model	Filter Quantity	Filter Item Code
ADC-3C_	1	CF_-7
ADC-4C_	1	CF_-8
ADC-5C_	1	CF_-9
ADC-6C_	2	CF_-10

- Please select carbon filter suitable for your application and the correct size for your ductless fume hood.
- For example if you are using an ADC-4B1 for organic application, you will need carbon filter code A for your needs. Therefore you should order 2 x CFA-2 for your ADC-4B1.

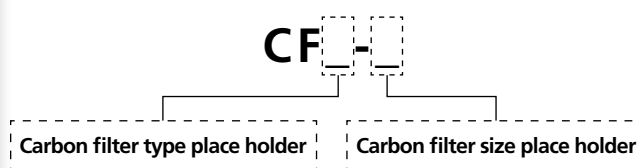

Choice of Carbon Filter Code		
Code	Name	Suitable Applications
A	Standard	All common Laboratory chemicals, especially with organics. When no specific requirements are present, or when more than one type of chemical is used
B	Acid	Applications involving sulphur dioxide, hydrofluoric acid fumes. Removes inorganic/organic acid vapours and fumes
C	Mercury	Highly effective for removal of mercury vapour and compounds. (Stable, non-volatile mercuric sulphide filter media)
D	Sulphur	Removal of sulphur compounds
E	Halogen	Removal of halogen compounds like Chlorine, Fluorine, Iodine, Bromine, Astatine etc.
F	Aldehyde	Formaldehyde applications or when aldehydes are present. Hospital pathology and endoscopy applications.
G	Ammonia/Amines	High performance removal of ammonia/amines by chemisorption



- Biological Safety Products
- Cleanroom Products
- Containment / Pharma Products
- Ductless Fume Hoods / Carbon Filtration
- General Purpose Scientific Equipment
- Industrial Lab Equipment
- In-Vitro Fertilization Products
- PCR Products
- Pharmacy Products
- Lab Animal Research Products
- Lab Thermostatics Products
- Lab Ventilation / Chemical Fume Products / Lab Furniture
- Powder Handling Products

*Since 1978, Esco has emerged as a leader in the development of controlled environment, laboratory and cleanroom equipment solutions. Products sold in more than 100 countries include biological safety cabinets, fume hoods, ductless fume hoods, laminar flow clean benches, animal containment workstations, cytotoxic cabinets, hospital pharmacy isolators, and PCR cabinets and instrumentation. With the most extensive product line in the industry, Esco has passed more tests, in more languages, for more certifications, throughout more countries than any biosafety cabinet manufacturer in the world. Esco remains dedicated to delivering innovative solutions for the clinical, life science, research and industrial laboratory community. [www.escoglobal.com](http://www.escoglobal.com).*

Airflow Alarms and Monitors • Biological Safety Cabinets • Exhaust Blowers  
 Benchtop Laboratory Fume Hoods • High Performance Low Flow Fume Hoods

# ESCO

WORLD CLASS. WORLDWIDE.

Esco Technologies, Inc. • 2940 Turnpike Drive, Units 15-16 • Hatboro, PA 19040, USA  
 Toll-Free USA and Canada 877-479-ESCO • Tel 215-441-9661 • Fax 215-441-9660  
[us.escoglobal.com](http://us.escoglobal.com) • [usa@escoglobal.com](mailto:usa@escoglobal.com)

Esco Micro Pte. Ltd. • 21 Changi South Street 1 • Singapore 486 777  
 Tel +65 6542 0833 • Fax +65 6542 6920 • [mail@escoglobal.com](mailto:mail@escoglobal.com)  
[www.escoglobal.com](http://www.escoglobal.com)

**Esco Global Offices** | Kuala Lumpur, Malaysia | Leiden, The Netherlands | Manama, Bahrain  
 Mumbai, India | Philadelphia, USA | Salisbury, UK | Shanghai, China | Singapore

